

www.electronicsrepair.net

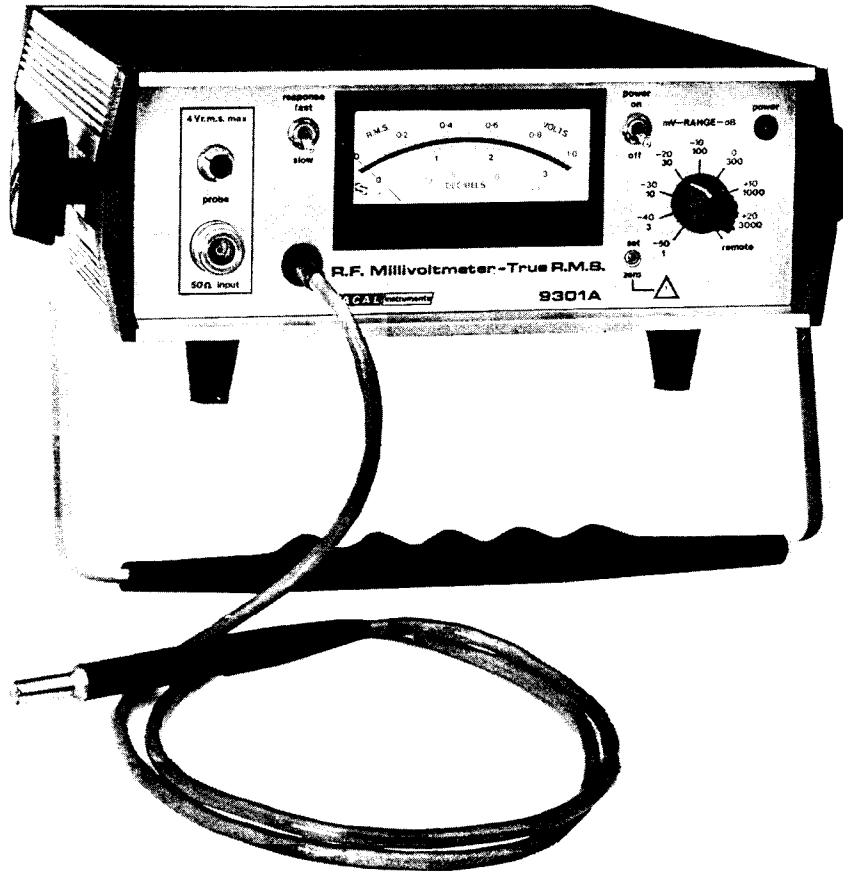

True R.M.S. Millivoltmeter
9301A

RACAL

CONTENTS

	<u>Page</u>
FRONTISPIECE	
SECTION 1 TECHNICAL SPECIFICATION	
SECTION 2 DESCRIPTION OPERATION & MAINTENANCE	
CHAPTER 1 GENERAL DESCRIPTION	
INTRODUCTION	1-1
PRINCIPLE OF OPERATION	1-1
THE PROBE UNIT	1-1
IN-BUILT 50Ω TERMINATION	1-2
DC OUTPUT	1-2
REMOTE PROGRAM CONTROL	1-2
CARRYING HANDLE AND BENCH STAND	1-2
CHAPTER 2 OPERATING	
INTRODUCTION	2-1
LOCAL CONTROL	2-1
REMOTE PROGRAM CONTROL	2-1
CONNECTION OF THE SIGNAL TO BE MEASURED	2-1
Measurements Using the Internal Termination	2-1
Measurements Using the High Impedance Probe	2-2
Using the Attenuators	2-3
In Line Measurements	2-4
CONTROLS INDICATORS AND CONNECTIONS	2-5
Front Panel Items	2-5
Rear Panel Items	2-6
CHAPTER 3 PRINCIPLES OF OPERATION	
INTRODUCTION	3-1

	<u>Page</u>
BASIC PRINCIPLE	3-1
FUNCTIONAL PRINCIPLES	3-1
Block Diagram	3-1
The Probe	3-1
Sweep Oscillator and Pulse Drive	3-2
RMS Conversion	3-2
Meter Drive and Response Select Switch	3-2
Probe Balance and Bias	3-2
Noise Cancel Logic	3-3
Offset Adjust	3-3
Internal 50Ω Termination	3-3
 CHAPTER 4 TECHNICAL DESCRIPTION	
 INTRODUCTION	 4-1
THE PROBE	4-1
PULSE AND SWEEP GENERATOR ASSEMBLY	4-1
Introduction	4-1
Sweep Generator	4-1
Pulse Drive Outputs	4-2
Anti-Jitter, Meter Drive and Response Selection	4-2
RMS Output	4-3
Noise Cancel Logic	4-3
Probe Balance and Bias Circuit	4-3
PROCESSOR PCB ASSEMBLY	4-4
Introduction	4-4
Variable Gain Amplifier	4-4
Attenuators	4-4
Attenuators Selection	4-4
Sample and Hold	4-5
Integrator	4-6
Precision Rectifier	4-6
Squaring and Averaging Circuit	4-6
Square Root and Hold Circuit	4-7
Response Select	4-7
Reading Hold	4-7
POWER SUPPLY	4-7

	<u>Page</u>
USE OF TEST EQUIPMENT	5-1
REMOVAL OF COVERS	5-1
NOTE TO MILITARY USERS	5-1
LIST OF TEST EQUIPMENT REQUIRED	5-2
POWER SUPPLY CHECKS	5-3
Fuse Check	5-3
Voltage Selection	5-3
CALIBRATION	5-5
Probe Check	5-5
Sweep Generator Checks	5-5
Probe Balancing	5-7
Setting-Up the RMS Circuits	5-9
Attenuator Check	5-10
Frequency Response (Probe)	5-12
Frequency Response (9301 Unit)	5-14
Isolator Check	5-15
Isolator Frequency Response	5-16
VSWR Check	5-17
Unit Frequency Response (Recheck)	5-18
Range Accuracy Setting Check and Noise Cancel Adjustment	5-18
Scale Linearity Check	5-19
Attenuator Test	5-21
T Piece Tests	5-22
PROBE REMOVAL	5-25
REMOVAL OF FRONT PANEL	5-26
REMOVAL OF REAR PANEL	5-26

IN TEXT ILLUSTRATIONS

<u>Fig. No.</u>		<u>Page</u>
2.1	Remote Program Socket Pin Identification	2-6
2.2, 2.3	Calibration Curves for Probe Terminated in 50Ω Load	2-7, 2-8
3.1	Probe and Input Connections for Internal 50Ω Termination	3-3
5.1	Test Waveform TP2: 19-0823	5-6
5.2	Test Waveform TP3: 19-0823	5-6
5.3	Test Waveform TP8: 19-0822	5-7
5.4	Test Waveform Pin 4: 19-0822	5-8
5.5	Test Waveform Pin 4: 19-0822	5-8
5.6	RMS Check Connections	5-9
5.6a	Test Waveform Pin 3: 19-0822	5-11
5.7	Frequency Response (Probe) Test Connections	5-13
5.7a	Test Waveform Pin 4: 19-0822	5-13
5.8	Frequency Response (9301A) Test Connections	5-14
5.9	Isolator Check Connections	5-16

<u>Fig.No.</u>		<u>Page</u>
5.10	VSWR Test Connections	5-17
5.11	20 dB and 40 dB Attenuator Test Connections	5-22
5.12	T Piece VSWR Check Connections	5-23
5.13	T Piece Insertion Loss Check Connections	5-24

LIST OF TABLES

<u>Table No.</u>		<u>Page</u>
1	Remote Program Coding	Tech. Spec. (3)
2	Noise Cancel Logic	4-3
3	Attenuator Selection Example	4-5
4	Attenuation Selection on Processor PCB	4-5
5	List of Test Equipment Required	5-2
6	Voltage Selection Switches	5-4
7	Attenuator Check	5-11
8	Frequency Response (9301 Unit)	5-15
9	Range Accuracy Checks	5-19
10	Scale Linearity Checks	5-20

SECTION 3 PARTS LISTS, COMPONENT LAYOUTS AND CIRCUIT DIAGRAMS

Chassis Layout: 9301 Topside View	Fig. 1
Chassis Layout: 9301 Underside View	Fig. 2
Parts List 1: Power Supply	
Circuit: Power Supply	Fig. 3
Parts List 2: Probe Assembly	
Component Layout: Probe PCB Assembly	Fig. 4
Circuit: Probe Assembly	Fig. 5
Parts List 3: Pulse and Sweep Generator Assembly	
Component Layout: Pulse and Sweep Generator PCB	Fig. 6
Circuit: Pulse and Sweep Generator Assembly	Fig. 7
Parts List 4: Processor Assembly	
Component Layout: Processor PCB	Fig. 8
Circuit: Processor Assembly	Fig. 9
Parts List 5: 50Ω Termination and Miscellaneous Items	
Overall Block Diagram	Fig. 10

TECHNICAL SPECIFICATION

VOLTAGE RANGES	1mV to 3V r.m.s. f.s.d. in 8 switchable ranges. Lowest reading 100 μ V.
MAXIMUM VOLTAGES	(1) 50 Ω socket: 4V (d.c. plus a.c.). (2) Probe: 9V peak a.c. plus up to 100V d.c.
FREQUENCY RANGE	10kHz to 1.5GHz (usable as an indicator to 2GHz).
INPUT IMPEDANCE	Probe: 100k Ω in parallel with less than 3pF. Probe with Isolator Tip: 100k Ω in parallel with less than 10pF. Internal Terminated Input: 50 Ω VSWR 1.1 to 1GHz.
BASIC ACCURACY	Probe used with internal 50 Ω load: $\pm 1\%$ of f.s.d. $\pm 1.5\%$ of reading (+20 $^{\circ}$ C to 25 $^{\circ}$ C). $\pm 3\%$ of f.s.d. $\pm 2\%$ of reading (0 $^{\circ}$ C to +40 $^{\circ}$ C).
FREQUENCY ERRORS	10kHz to 500MHz: Nil 500MHz to 1GHz: $\pm 5\%$ of reading * 1GHz to 1.5GHz: $\pm 15\%$ of reading * * Above 500MHz the appropriate calibration curve in Fig.2.2 or Fig.2.3 must be applied when measuring with 50 Ω load.
CREST FACTOR	12dB at f.s.d. on all ranges up to 1V, increasing inversely for readings below f.s.d. (for example, 18dB at half scale).
READING HOLD	Press-to-hold switch on probe holds reading to within 0.5% for 3 minutes.
DC OUTPUT	-1V for f.s.d. from 1k Ω source impedance.
POWER SUPPLY	a.c.: 94V to 130V and 188V to 260V. 45-440Hz. d.c.: plus and minus 17V to 25V. Consumption: 8VA approximately.

Tech.Spec.(1)

TEMPERATURE RANGE

Operating: 0°C to +55°C.
Storage: -40°C to +70°C.
Humidity: 95% r.h. at +40°C.

	<u>Height</u>	<u>Width</u>
Case only:	83mm	240mm
Overall:	110mm	284mm
<u>Depth:</u>	268mm	
<u>Weight:</u>	2.5kg	

ACCESSORIES SUPPLIED

Isolator Tip 11-1151. Accuracy: Add ± 3% reading from 10kHz to 200MHz.

Flexible Earth Lead 11-1160.

H.F. Earth Clip-Prod 13-1520

Remote Control Connector 11-1161.

2 Spare Probe Tips 14-1459.

Power Fuse (94-130V operation).

Power Lead.

OPTIONAL ACCESSORIES

20dB Attenuator. Accuracy: Add ± 6%
11-1155 reading from 10kHz to 500MHz.
Input impedance 100kΩ
in parallel with less
than 3pF.

NOTE: Before using the 40dB Attenuator, refer to the warning on page 2-4.

40dB Attenuator. Accuracy: Add ± 6%
11-1156 reading from 1MHz to 500MHz.
Input impedance less than 3pF.

50-75Ω Adaptor. Attenuation 10dB.
23-3230

Probe/BNC Adaptor 11-1131.

Accessory Box 11-1162.

Carrying Case 15-0434.

Probe 'T' Assembly 11-1353 (see page 2-4).

REMOTE PROGRAM

Remote programming is selected by the REMOTE position on the front panel 'Range' switch. The remote program BCD control is fed in via the rear panel remote control socket. Levels are TTL compatible and may be taken to a maximum of +70V for a '1' state and -70V for a '0' state without damage to the instrument. The encoding details are in Table 1 below.

TABLE 1

Remote Program Coding

Ranges	Connector Pin Numbers and Logic Levels		
	Pin 1	Pin 2	Pin 3
1 mV/-50 dB	0	0	0
3 mV/-40 dB	1	0	0
10 mV/-30 dB	0	1	0
30 mV/-20 dB	1	1	0
100 mV/-10 dB	0	0	1
300 mV/0 dB	1	0	1
1V/+10 dB	0	1	1
3V/+20 dB	1	1	1

NOTE: To revert to local control set inputs to '0' level, or disconnect the remote program connector.

CHAPTER 1

GENERAL DESCRIPTION

INTRODUCTION

- 1.1 The 9301A is a wide-band millivoltmeter of exceptional accuracy and advanced design, providing true r.m.s. measurements of r.f. sinusoidal, pulse and noise waveforms.
- 1.2 The frequency range is 10kHz to 1.5GHz and useful indications are obtainable up to 2GHz. The meter has two voltage scales, and a 'dB' scale referenced to 0dBm into 50Ω. Voltages from 100μV to 3.0V can be measured in eight ranges selected by switch or remote program. Attenuator options are available to extend the measurement range to 30V and 300V at frequencies below 500MHz. Fast and slow meter responses can be selected by a front panel switch.
- 1.3 The instrument operates from a.c. power supply. Provision is made for the connection of a customer's d.c. power supply via rear panel terminals. Reverse polarity protection by series diodes is built into the instrument.
- 1.4 Measurements are made via the attached probe, as described in para. 1.8. A 50Ω termination is provided within the instrument, or an external 50Ω load can be used by means of an optional BNC adaptor or 'T' Piece accessory. The use of the various accessories is described in Chapter 2.

PRINCIPLE OF OPERATION

- 1.5 The 9301A employs a random sampling system in which the amplitude of the random sampling output is proportional to the input signal level at the instant of sampling.
- 1.6 The sampling process is followed by r.m.s. conversion which gives true r.m.s. reading at all frequencies and over the complete voltage measuring range.

THE PROBE UNIT

- 1.7 The Probe Unit, which is permanently connected to the instrument, is used for all measurements and has an input impedance of 100kΩ in parallel with less than 3pF. It incorporates a sampling circuit that is linear to below 100μV, it has a frequency response which is virtually flat to 1.5GHz, and an operating temperature range which is the same as the main instrument. A press-to-hold button on the probe allows a reading to be stored at an accuracy of ± 0.5% for up to 3 minutes. Stowage clips for the probe and cable are mounted on the underside of the instrument.

1.8 The probe is calibrated for accurate measurements in terminated 50Ω systems, and such measurements may be made either by using a Probe/BNC adaptor (optional accessory) with the customer's own external 'T' piece and 50Ω load, or by using the internal 50Ω termination. Calibration curves are provided for use with 50Ω loads at frequencies above 500MHz. A Probe 'T' Piece accessory is available.

1.9 At lower frequencies accurate measurements may be made in other than 50Ω systems by employing the Isolator Tip supplied. Refer to the technical specification for performance data. Optional attenuator tips are available to extend the voltage range of the instrument to 30V and 300V.

IN-BUILT 50Ω TERMINATION

1.10 Accurate measurements in 50Ω circuits may be made by means of the internal 50Ω termination. To use this facility, the probe is inserted into the front panel PROBE socket and the signal is applied to the adjacent 'N' type socket (50Ω INPUT). This provides a 50Ω termination in a convenient and readily available form. The accuracy under these conditions is given in the technical specification. Above 500MHz the appropriate calibration curve must be used.

1.11 Measurements may also be made in 75Ω circuits via the internal 50Ω termination, by using the optional 50Ω/75Ω adaptor. The adaptor introduces a precise 10dB of attenuation, and thus moves all meter readings down by the equivalent of one step of the range switch.

DC OUTPUT

1.12 A d.c. output corresponding the r.m.s. value of the input signal is available from a rear panel BNC socket for connection to a digital voltmeter, d.c. recorder or other processor. The d.c. output is -1V at the meter f.s.d. on any range.

REMOTE PROGRAM CONTROL

1.13 All voltage ranges are remotely programmable, using a standard BCD code at TTL compatible levels, applied via three lines to a multiway connector on the rear panel. The BCD coding is given on page Tech.Spec.(3). This facility and the d.c. output, enable the 9301A to be incorporated directly in automatic test equipment systems. The fast and slow meter response facility is not selectable by remote control.

CARRYING HANDLE AND BENCH STAND

1.14 The combined carrying handle and bench stand can be set in several position. To change the position press in both handle bosses simultaneously (they are marked PUSH) at the same time moving the stand to the required position for bench operating, or carrying.

CHAPTER 2

OPERATING PROCEDURE

INTRODUCTION

2.1 The instrument should be prepared for use in accordance with the instructions in Chapter 3 of the Operators Handbook. If the instrument is being used for the first time, or at a new location, pay particular attention to the setting of the supply voltage selector switches.

LOCAL CONTROL

- 2.2 (1) Switch POWER to ON and check that the indicator lights.
- (2) Select the required range and meter response.
- (3) Connect the signal to be measured to the 9301A in accordance with the instructions given in paragraph 2.4.

REMOTE PROGRAM CONTROL

- 2.3 (1) Prepare the remote control connections in accordance with the instructions on page 2-6.
- (2) Switch POWER to ON and check that the indicator lights.
- (3) Select the required meter response.
- (4) Set the RANGE switch to remote and select the required range at the remote program control point.
- (5) Connect the signal to be measured to the 9301A in accordance with the instructions given in paragraph 2.4.

CONNECTION OF THE SIGNAL TO BE MEASURED

2.4 The signal to be measured is sampled by means of the probe. The following paragraphs give instructions for connecting the signal to be measured to the probe, using the probe accessories. The accessories should only be used in the manner described.

Measurements Using the Internal Termination

2.5 The recommended method of making measurements, which gives the greatest accuracy, is with the signal to be measured terminated using the internal 50 Ω load of the 9301A.

- (1) Connect the signal to the front panel 50Ω INPUT socket, using 50Ω coaxial cable.

CAUTION: THE MAXIMUM PERMITTED SIGNAL IS 4V
(DC + peak AC).

- (2) Insert the probe, without accessories attached, into the PROBE socket. The instrument will now measure the signal across the 50Ω load.
- (3) At frequencies above 500MHz, scale the reading obtained according to the instrument's individual calibration curve. The calibration curve will be found in the pouch secured to the bottom panel. Measurements made with instruments for which individual calibration curves are not provided should be scaled according to curve A of Fig.2.2 or curve C of Fig.2.3

- 2.6 A 75Ω to 50Ω adaptor, Racal-Dana part number 23-3230, is available as an optional accessory. This may be inserted in the 50Ω INPUT socket of the 9301A to provide a termination for 75Ω systems. When the adaptor is used 10 dB must be added to the measurements made. This should be done after scaling the meter reading as instructed in paragraph 2.5(3).

Measurements Using the High Impedance Probe

- 2.7 Often the circuit on which measurements are to be made cannot be loaded with 50Ω, or connection of the circuit to the 50Ω INPUT socket is impracticable. In these cases measurements at frequencies in the range from 10 kHz to 200 MHz can be made by connecting the probe across the circuit in the following manner:-

- (1) Fit the Isolator Tip (Racal-Dana part number 11-1151) to the probe. This prevents the accuracy of the probe being affected by the source impedance of the signal being measured.
- (2) Ground Connection - Frequencies below 10 MHz.
Fit the HF earth clip or the flexible earth lead and clip to the body of the isolator.
- (3) Ground Connection - Frequencies from 10 MHz to 200 MHz.
Fit the HF earth clip to the body of the isolator.

- (4) Connect the relevant earth clip to the common line and the isolator tip to the signal line of the circuit under test.
- (5) If required, the probe, with the isolator tip attached, may be connected to BNC systems using the optional Probe-to-BNC adaptor, Racal-Dana part number 11-1131.

Using the Attenuators

2.8 Two attenuators of 20 dB and 40 dB, Racal-Dana part numbers 11-1155 and 11-1156, are available as optional accessories. Both attenuators plug onto the end of the probe, (the isolator tip should NOT be used) and may be used to make measurements from any source impedance.

WARNING: DANGEROUS VOLTAGES MAY BE INDUCED IN THE PROBE BODY WHEN MAKING HIGH VOLTAGE MEASUREMENTS AT HIGH FREQUENCY. OBSERVE THE FOLLOWING PRECAUTIONS:

- (1) ENSURE THAT THE ATTENUATOR BODY IS PROPERLY EARTHED AT THE POINT OF MEASUREMENT.
- (2) DO NOT HOLD THE PROBE WHEN MAKING HIGH VOLTAGE MEASUREMENTS.
- (3) USE THE PROBE-TO-BNC ADAPTOR IN ADDITION TO THE ATTENUATOR WHENEVER POSSIBLE.

The frequency ranges and maximum permitted inputs are as shown in the following table:-

Attenuator Characteristics

	Frequency Response	Max. Input	Input Impedance
20 dB	10 kHz to 500 MHz	30V	100kΩ in parallel with less than 3 pF
40 dB	1. MHz to 500 MHz	300V	Less than 3 pF

- 2.9 When an attenuator is used without the Probe-to-BNC adaptor connect the probe and attenuator to the circuit under test as follows:-
- (1) Ground Connection - Frequencies below 10 MHz.
Fit the HF earth clip or the flexible earth lead and clip to the body of the attenuator.
 - (2) Ground Connection - Frequencies from 10 MHz to 500 MHz.
Fit the HF earth clip to the body of the attenuator.
 - (3) Connect the earth clip to the common line and the attenuator tip to the signal line of the circuit under test.

In-Line Measurements

- 2.10 In-line measurements in 50Ω systems are made using the Probe T Assembly, Racal-Dana part number 11-1353.
- 2.11
- (1) Connect the Probe T Assembly into the system on which measurement is to be made, using the type N connectors.
 - (2) Insert the probe, without accessories attached, into the receptacle at the side of the assembly.
 - (3) At frequencies above 500 MHz scale the readings obtained, first according to the instrument's individual calibration curve and then using Curve E of Fig 2.3. When using an instrument not fitted with an individual calibration curve, scale the readings obtained according to Curve B of Fig 2.2 or Curve D of Fig 2.3 only.
- 2.12 In-line measurement may also be made using the Probe-to-BNC adaptor and a BNC T piece. The calibration of the instrument cannot be guaranteed when this method is used, because the loading effect of the probe and accessories is not compensated for in the BNC T piece.
- 2.13
- (1) Insert the BNC T piece into the system on which measurements are to be made.
 - (2) Fit the probe with either an attenuator, if this is required, or with the isolator tip.
 - (3) Connect the probe to the T piece using the Probe-to-BNC adaptor.

CONTROLS INDICATORS AND CONNECTIONS

FRONT PANEL ITEMS

POWER ON/OFF Switch	A two-pole toggle switch which switches the transformer secondary supplies to the power rectifiers. The external d.c. supply path is not switched in the instrument.
RANGE Switch	A b.c.d. coded switch which switches in a 70 dB attenuator in 10 dB steps. The voltage range markings are in black and the 'dB' markings in red. The switch also selects REMOTE program control.
RESPONSE SWITCH	In the FAST position the meter indicates within the specified accuracy in less than 0.8 seconds. In the SLOW position the meter indicates within the specified accuracy in less than 3 seconds.
CALIBRATE Adjuster (SET ZERO in earlier models)	This screwdriver adjustment permits zero setting of the meter pointer by cancelling internal circuit 'noise'.
Meter	<p>The Meter is scaled:-</p> <ul style="list-style-type: none">(i) 0 to 1.0V(ii) 0 to 3.2V(iii) -12 to +3 dB <p>The units of voltage measurement should be interpreted according to the range selected by the switch.</p> <p>The dB scale is referenced to 0 dBm (1 mW into 50Ω). For example, if the 20 dB range is selected, an input level of +20 dBm would give a meter reading of zero. A +23 dBm input level would give a +3 dB reading.</p>
50 Ω INPUT Socket	This input is connected to the internal 50 Ω Termination Assembly. Fig. 3.1 on page 3-3 shows the relationship between the Probe, the Probe socket and the 50 Ω input socket.
The Probe Unit	The Probe Unit, which is stowed in clips on the underside of the instrument, is used for all measurements. It has an input impedance of 100 k Ω in parallel with less than 3 pF. It incorporates a sampling circuit and a 'press to hold' button by which a reading can be stored to within $\pm 0.5\%$ for 3 minutes. Accessories supplied for use with the probe are a flexible earthing lead and clip-prod, an isolator tip, and two spare probe tips. Optional accessories available are listed in the Technical Specification and described in paras. 2.4 to 2.12.

PROBE Socket

By plugging the probe into the PROBE socket a connection is made to the internal 50Ω termination. When this 50Ω termination is in use a calibration curve must be used at frequencies above 500 MHz.

REAR PANEL ITEMS

Power Input Plug (a.c.)

A 3-pin fixed plug of the IEC type. A power lead with mating connector is supplied with the instrument.

AC Supply Fuse

The fuse is a glass cartridge anti-surge type, 20 x 5mm. The required rating is marked on the panel.

Voltage Selection Switches

Two slide switches with locking plate provide four a.c. voltage ranges. Setting instructions are in chapter 5.

DC Supply Terminals

Three screwed terminals marked +20V, 0V, -20V provide for the connection of an external d.c. supply with centre tapped earth.

DC OUTPUT Socket (BNC)

Provides a -1V output at f.s.d. on the 0 to 1 scale of the meter (or at a reading of 3.162 on the 0.3 to 3.2 scale).

REMOTE INPUT Socket

A 9-way socket, of which only pins 1, 2 and 3 are used, to carry attenuator control instructions to the instrument in b.c.d. code at TTL levels. The range selection code is given in the technical specification. To revert to local control the input lines must be set to 'all '0' state', or the input plug disconnected. Fig. 2.1 below shows the pin identification diagram.

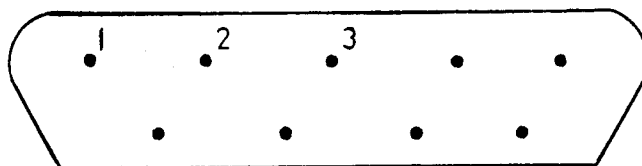

Remote Program Socket Pin Identification
(Viewed On Rear Panel)

Fig. 2.1

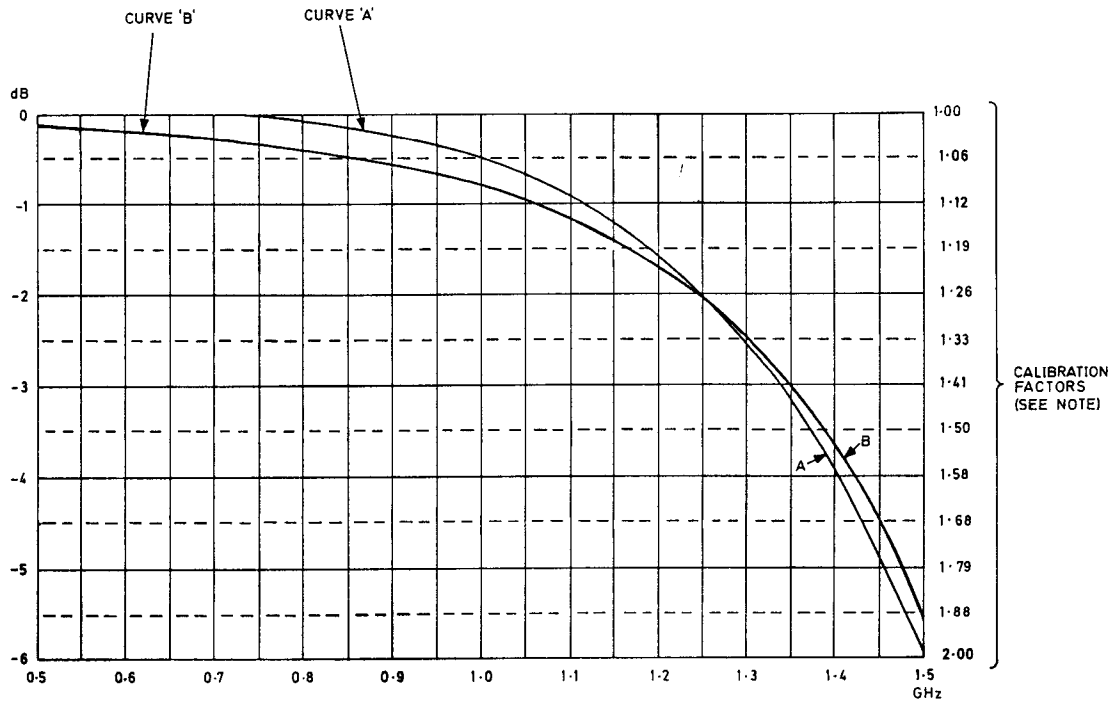

- NOTES: 1. TO OBTAIN THE TRUE MEASUREMENT MULTIPLY THE METER READING BY THE APPROPRIATE CALIBRATION FACTOR.
2. CURVE 'A' APPLIES TO THE 50Ω INTERNAL LOAD.
CURVE 'B' APPLIES TO 'T' PIECE ACCESSORY 11-1353
3. USE THESE CURVES FOR INSTRUMENTS WITH SERIAL NUMBERS UP TO 2659 WHICH ARE NOT FITTED WITH INDIVIDUAL CALIBRATION CURVES.



Calibration Curves for Probe Terminated in 50Ω Load

Fig.2.2

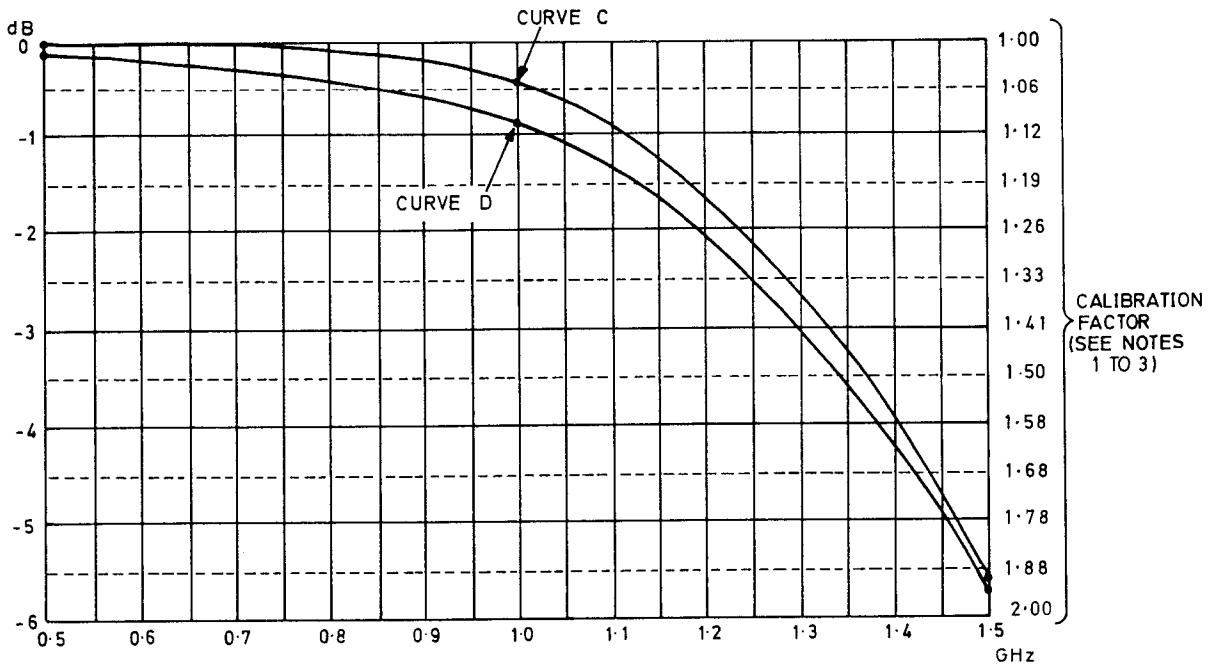
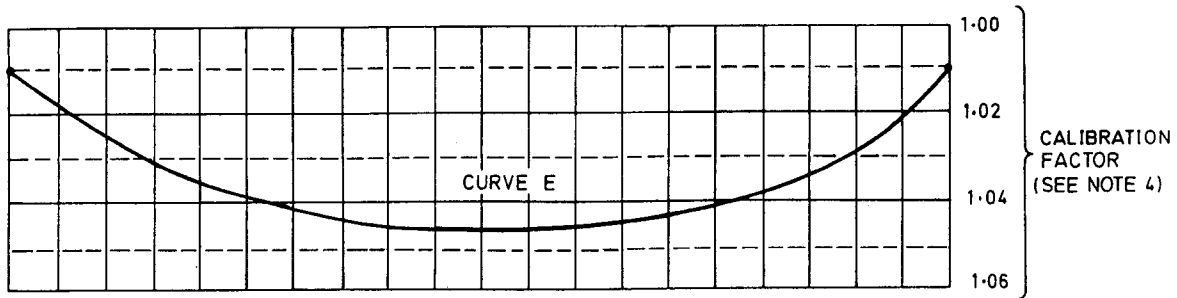

- NOTES
1. TO OBTAIN THE TRUE MEASUREMENT MULTIPLY THE METER READING BY THE APPROPRIATE CALIBRATION FACTOR.
 2. CURVE C APPLIES TO THE 50 Ω INTERNAL LOAD.
CURVE D APPLIES TO 'T' PIECE ACCESSORY 11-1353
 3. USE CURVES C AND D FOR INSTRUMENTS WITH SERIAL NUMBERS ABOVE 2659 WHICH ARE NOT FITTED WITH INDIVIDUAL CALIBRATION CURVES.
 4. CURVE E APPLIES TO 'T' PIECE ACCESSORY 11-1353. USE THIS CURVE FOR INSTRUMENTS FITTED WITH INDIVIDUAL CALIBRATION CURVES. THE CALIBRATION FACTOR FOR THIS CURVE IS A MULTIPLIER, WHICH SHOULD BE APPLIED AFTER SCALING THE READING ACCORDING TO THE INSTRUMENTS INDIVIDUAL CALIBRATION CURVE.

Calibration Curves For Probe Terminated in 50 Ω Load

WOH 8166	9301A
1	2 3 4

Fig.2.3

CHAPTER 3

PRINCIPLES OF OPERATION

INTRODUCTION

3.1 The 9301A consists of the following circuitry.

- (1) The sweep oscillator and measuring circuits which are mounted on two printed circuit boards (the Pulse and Sweep Generator Assembly 19-0823 and the Processor Assembly 19-0822). These are contained in a cast module.
- (2) The Probe, which contains the sampling circuit.
- (3) The power supply circuit, which comprises a number of separate items, connected to tag strips and mounted directly on the metalwork of the instrument.
- (4) A 50Ω internal termination. (see page 3-3).
- (5) External accessories for attachment to the probe.

BASIC PRINCIPLE

3.2 A sweep oscillator drives a pulse generator which continuously samples the amplitude of the external signal at the probe. The sampled voltages are fed via step attenuators (for range selection) to a sample and hold circuit which operates in synchronism with the probe sampler.

3.3 The d.c. voltage thus obtained is applied to a sequence of logarithmic detectors, which converts the sample/hold voltage to a root mean square (r.m.s.) value to drive the meter.

FUNCTIONAL PRINCIPLES

Block Diagram

3.4 The functional principles are described with reference to the Block Diagram (Fig. 10) at the back of the book.

The Probe

3.5 Referring to the Block Diagram (Fig. 10) the probe contains a diode sampling bridge in which the external signal is applied to one terminal of the bridge. Two other terminals are fed with a continuous, but random, train of narrow sampling pulses, supplied from a sweep oscillator via a pulse generator.

- 3.6 Each sampling pulse forward-biases the bridge, which allows the instantaneous level of the input signal to be transferred to the Processor p.c.b. for measurement.

Sweep Oscillator and Pulse Drive

- 3.7 Referring to Assembly 19-0823 in Fig. 10, the sweep oscillator is driven by a sawtooth waveform generated by a multivibrator and integrator, such that the oscillator frequency sweeps between the limits of approximately 12.5kHz and 25kHz at a 10Hz rate.
- 3.8 The oscillator output is converted by a monostable to narrow pulses, and fed via the pulse drive circuit to the sample-and-hold and clamp circuit in the Processor p.c.b. and to a pulse generator in the probe.

RMS Conversion

- 3.9 The output from the sampler in the probe is fed to a variable gain amplifier on the Processor p.c.b., where range selection is provided by three switched attenuators which provide attenuation from 0dB to 70dB in 10dB steps, selected by the front panel Range control (or by remote program).
- 3.10 The amplifier output is fed to a sample-and-hold circuit (driven in synchronism with the sampler in the probe) which provides an output voltage for application to the r.m.s. stages.
- 3.11 A clamp circuit driven by the pulse drive circuit, inhibits the measurement path during each sampling pulse thus preventing unwanted interference from reaching the meter. In between the sampling pulses the voltage at the sample/hold point is released to the precision rectifier, which drives the squarer/averager and square root detectors for r.m.s. conversion.
- 3.12 The square root detector output has a hold circuit, which can be activated by the Hold button on the probe, thereby retaining the measurement voltage for a period of at least three minutes.

Meter Drive and Response Switch

- 3.13 The meter is driven via the anti-jitter and meter drive circuit which, by operation of the front panel RESPONSE switch, provides fast or slow meter response. In the SLOW position the circuit responds only slowly to very small signal changes, and thus reduces the effect of 'jitter'. In the FAST position the circuit capacitance is reduced in the meter output and averager circuit, which increases the speed of response.

Probe Balance and Bias

- 3.14 A common d.c. (earth) reference level is maintained at the sample/hold in the Processor p.c.b., and in the probe. This reference is produced in the integrator loop in the Processor p.c.b. and fed to the probe via the balance and bias circuit in the Sweep and Pulse Generator p.c.b.

Noise Cancel Logic

3.15 The noise cancel circuit operates on the 1 mV and 3 mV ranges and is selected automatically by logic signals on the Range (attenuator) control lines. The circuit applies a negative voltage to the square root detector sufficient to cancel internal 'noise'. The front panel Set Zero (screwdriver) adjustment provides for accurate setting of the noise cancelling facility.

Offset Adjust

3.16 This is an adjustable potential divider which provides compensation for the 'offsets' at the various operational amplifiers in the square law detector.

Internal 50Ω Termination

3.17 The relationship between the Probe socket on the front panel, the 50Ω INPUT socket and the internal 50Ω termination is shown in Fig. 3.1 below.

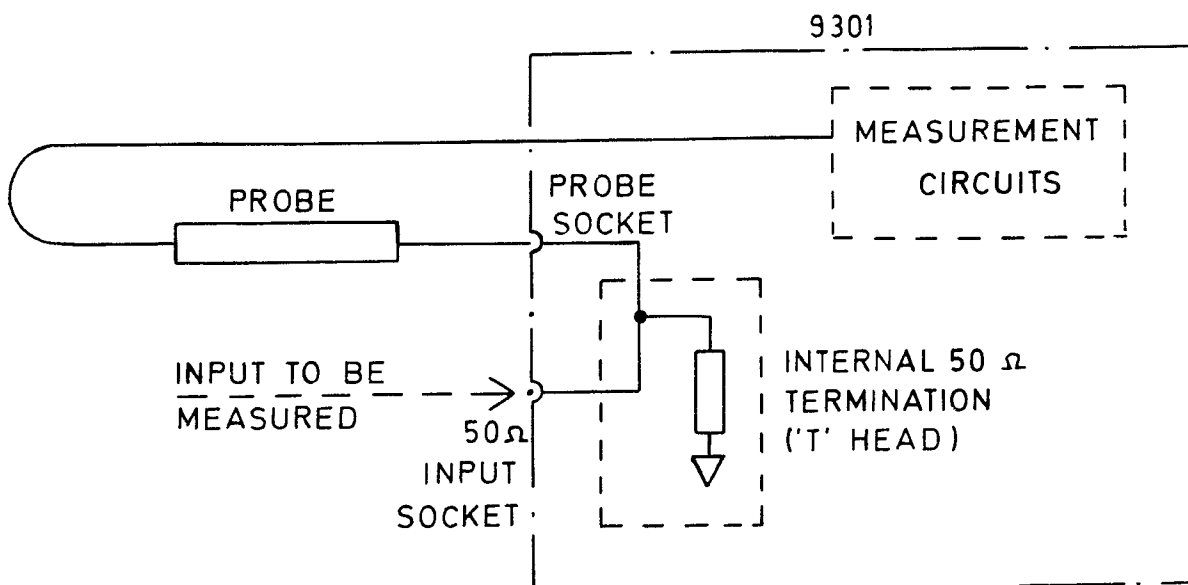

Probe And Input Connections
For Internal 50Ω Termination

Fig. 3.1

CHAPTER 4

TECHNICAL DESCRIPTION

INTRODUCTION

4.1 It is assumed that the reader has a sound knowledge of solid state circuit principles and has studied the basic principles of the instrument described in Chapter 3.

THE PROBE

4.2 Referring to the circuit diagram, Fig. 5, the probe circuit comprises a diode sampling bridge D1 to D4, a step-recovery diode pulse generator D5 and an output stage Q1. The external signal is applied via the probe tip and C1/R1 to the junction of D1/D2.

4.3 The pulse drive at pad 3 swings between 0.7V and -15V with a pulse width of approximately 2.5 μ s. The negative leading edge of each pulse reverse biases the step recovery diode D5, which snaps off, thus causing the energy stored in inductor L1 to produce a positive pulse about 300 ps wide. This pulse is applied via C3 to the transmission line transformer T1 which produces symmetrical anti-phase sampling pulses (positive at the junction D2/D4 and negative at D1/D3).

4.4 A standing reverse bias is applied to the sampling bridge via resistors R6 and R7. The anti-phase sampling pulses briefly overcome this reverse bias, thus allowing the instantaneous voltage of the probe input signal to feed current to the gate of the FET Q1. The gate circuit capacitance of Q1 is sufficient to retain this charge for a short time after each sampling pulse. Resistor R3 discharges the capacitance in readiness for the next sampled input.

PULSE AND SWEEP GENERATOR ASSEMBLY (19-0823)

Introduction

4.5 Referring to the circuit diagram Fig. 7, the upper half of the diagram refers to the sweep generator and pulse drive system, whereas the lower half shows three independent sub-circuits concerned with probe bias, noise cancelling and meter drive.

Sweep Generator

4.6 The sweep oscillator is the unijunction Q6 whose frequency is varied continuously (at a 10 Hz rate) between the limits 12.5 kHz and 25 kHz approximately. The 10 Hz sweep is determined by the multivibrator circuit of Q1/Q2 which drives the integrator circuit centred on Q3. This produces at TP2 a 10 Hz triangular voltage waveform with an amplitude of 0V to +7V approximately.

4.7 This voltage waveform is converted by Q4 into a current triangular waveform which charges capacitor C4. The frequency of the unijunction oscillator Q6 is determined by the rate of charge of C4, thus a swept frequency is produced which triggers the monostable Q7/Q8 via capacitor C5.

4.8 The monostable is formed by Q7/Q8 and associated components. Temperature compensation to maintain a stable pulse width is provided by transistor Q5. The pulse width of the monostable output is variable by R13 from 1 μ s to 3 μ s.

Pulse Drive Outputs

4.9 The output from the monostable at Q7 collector is fed via R17 to the differential pair Q9/Q10 which provides separate outputs to the sample/hold circuit and clamp circuit respectively in the Processor p.c.b. A monostable output is also fed via R25 to the pulse amplifier and shaper Q11/Q12/Q13 for sampling drive in the probe.

4.10 These pulse drive outputs have the following nominal characteristics.

- (1) To the sample/hold: width 2.5 μ s and amplitude -0.7V to +15V, at pin 5.
- (2) To the clamp: width 2.5 μ s and amplitude -12V to +6V, at pin 3.
- (3) To the probe (at pin 10): width 2.5 μ s. The amplitude with the probe disconnected is +15V to -15V peak to peak, but in the normal conditions (probe connected) the step recovery diode in the probe clamps the drive to +0.7V thus giving an effective amplitude of +0.7V to -15V.

Anti-Jitter, Meter Drive and Response Selection

4.11 The RMS output from the Square Root and Hold circuit in the Processor p.c.b. (Fig.9) is fed into the anti-jitter and meter drive circuit (Fig.7) which consists of amplifier IC2 and associated circuitry. The d.c. gain of this amplifier is unity.

Anti-Jitter

4.12 Referring to the circuit diagram Fig.7, the RMS output from 19-0822 is fed in on pin 18 and applied to the operational amplifier IC2/2 via IC4. The potentiometers in R88 permit fine adjustment of the system gain on certain ranges. The potentiometers are brought into circuit by the multiplexer IC3, according to the logic levels set on the attenuator control lines. The output from IC4 is applied to the operational amplifier IC2 via Q20 (conducting) C24, D10/D11 and via R62 in parallel. Anti-jitter protection occurs because very small a.c. signals are unable to turn on D10 and D11, and the overall gain for these signals is limited by R62 to only $\times 10^{-1}$. Larger signal changes which can turn on D10 and D11 will, however, receive unity gain. The function of Q20 is described in the next paragraph.

Response Select

4.13 With the front panel RESPONSE switch set to SLOW the anti-jitter circuit operates as described in the previous paragraph. When the RESPONSE switch is set to FAST it applies -15V via pin 25 to the junction of diodes D17/D18 (Fig.7). This negative voltage turns off Q20 (via D16) and Q21 (via D17) which removes the shunts from the series capacitors C23 and C30. This effective reduction of capacitance speeds up the meter response. The -15V is also applied via D18 to the Processor p.c.b. (see para. 4.37).

RMS Output

4.14 The output from IC2 is fed to the rear panel DC output via potential divider R66/R67 which provides a d.c. output of -1V at full scale deflection (f.s.d.) on the meter. The meter is fed via R68, and the potentiometer R69, which provides for meter f.s.d. setting.

Noise Cancel Logic

4.15 Instrument 'noise' produces a constant voltage at the output of the squarer stage in the Processor p.c.b., when the 1mV or 3mV ranges are in use. When either of these ranges is selected the Noise Cancel circuit produces an appropriate negative voltage which cancels the effect of instrument noise.

4.16 The noise cancelling circuit is controlled by logic signals (from the Processor p.c.b) on the 10dB, 20dB and 40dB lines. These logic signals (after inversion in Q6, Q12 and Q18, Fig. 9) are:-

TABLE 2
Noise Cancel Logic

Range Selected	Logic Signals to Noise Cancel Circuit		
	10dB	20dB	40dB
1mV	1	1	1
3mV	0	1	1

4.17 The 20dB and 40dB logic inputs turn on Q16 which feeds noise cancelling current via R57, pin 19 and the front panel 'Set Zero' potentiometer to the square root detector (Fig. 9 IC12) in the Processor p.c.b.

4.18 On the 1mV range, Q14 is turned off by the '1' on the 10dB line, Q15 is therefore off and Q17 is off. On the 3mV range, however, the '0' at pin 7 reverses these transistor states, causing Q17 to draw current from the noise cancel path via R58 and R59, thus reducing the noise cancelling effect by 10dB which can be precisely set by R58.

Probe Balance and Bias Circuit

4.19 The d.c. reference level established by the integrator in the Processor p.c.b. (Fig. 9 IC2) is fed via R75 and R37 to the amplifier IC1, which provides correctly balanced positive and negative bias voltages (+Vb and -Vb) for the probe sampling bridge.

4.20 The amplifier IC1 is fed with the correct d.c. reference level from the integrator in the Processor p.c.b. (Fig. 9, IC2) and the output is fed to a resistor network in which R44 sets the balance and R47 the bias level. The outputs are fed via pins 12 and 13 to the probe. The FET Q18 is a switch, controlled by Q19 in the Noise Cancel circuit. When the 1mV and 3mV ranges are selected Q16 conducts, which turns on Q19. The collector of Q19 goes negative which turns off Q18 and thus modifies the bandwidth of IC1 by open circuiting the feedback loop via C28. This maintains the correct d.c. balance at the probe.

PROCESSOR PCB ASSEMBLY (19-0822)

Introduction

4.21 The Processor p.c.b. receives the sampled signal from the probe and carries out range (attenuation) selection, a second stage of sampling, and conversion to a true r.m.s. output for the meter drive.

Variable Gain Amplifier

4.22 Referring to the circuit diagram, Fig. 9, the signal from the probe is applied via C2 to the input amplifier Q2/Q4/Q5 which offers a high impedance to the probe output and provides a low impedance output to the attenuator stage at TP1. Transistor Q1 is a current source for the FET in the probe (Fig. 5, Q1).

Attenuators

4.23 The 20dB, 40dB and 10dB attenuators are basically similar. The low impedance signal at TP1 is fed via C8 to a potential divider R19, R20 and R21. Part of this 20dB attenuator is shunted by the FET switch Q7, which is controlled by the local Range (or remote program) logic applied to Q6. When Q7 conducts, R19 and R20 are bypassed and the signal at TP1 is transferred to the base of Q8 without attenuation.

4.24 Amplifier Q8/Q10/Q11 provides an overall gain of x10 with a low impedance output via TP2 to the 40dB attenuator. Refer to the description in the preceding paragraph. The 10dB attenuator differs only in that it feeds into a wide band operational amplifier IC1 which drives the sample/hold stage Q22/C17.

Attenuator Selection

4.25 The three attenuator stages form a step attenuator capable of inserting 0dB to 70dB in 10dB steps which are selected by appropriate logic signals. Control logic is applied via the front panel Range switch and pins 7, 10 and 12 to the bases of Q6, Q12 and Q18 respectively, or, on remote program via pins 8, 9 and 11 and Q3, Q9 and Q15. The logic encode for local control is given in Table 4 on page 4-5. The encode for remote program connections is given in Table 1 on page Tech. Spec. (3).

4.26 The basic meter range is 1mV for full scale deflection with no attenuation inserted. The Range switch then inserts 10dB at each step to a maximum of 70dB on the 3V range, as shown in Table 4. An example (Table 3) illustrates the circuit action in the Processor p.c.b., using a Range setting of 300mV.

TABLE 3

Attenuator Selection Example

(Using Range 300 mV/0 dB)

Program Logic		Transistor States		Attenuator States
Pin 7	0	Q 6 off	Q 7 on	20 dB 'out'
Pin 10	1	Q12 on	Q13 off	40 dB 'in'
Pin 12	1	Q18 on	Q19 off	10 dB 'in'

TABLE 4

Attenuator Selection on Processor PCB

Range Switch	Attenuation Inserted (dB)	Connector Pins, Logic Levels and Attenuators on Processor PCB		
		Pin 7 (20 dB)	Pin 10 (40 dB)	Pin 12 (10 dB)
1 mV/-50 dB	0	0	0	0
3 mV/-40 dB	10	0	0	1
10 mV/-30 dB	20	1	0	0
30 mV/-20 dB	30	1	0	1
100 mV/-10 dB	40	0	1	0
300 mV/0 dB	50	0	1	1
1V/+10 dB	60	1	1	0
3V/+20 dB	70	1	1	1

Sample and Hold

4.27 The output from the stepped attenuator is fed via IC1 to the sample and hold stage Q22/C17. The pulse drive, fed in via Q20 and Q21, switches Q22 on and off in synchronism with the sample rate in the probe. The 'hold' capacitor C17 receives a charge during each sampling pulse and the resultant voltage across C17 is applied to the high input impedance amplifier Q23/Q24.

4.28 The output from Q24 is fed to an integrator loop (IC2) and via Q26 to the precision rectifier (IC3). During each sampling pulse these outputs are inhibited by the positive-going clamp drive pulse (via pin 20) which turns on Q25 and clamps the output line at TP7 to earth for the duration of the 2.5 μ s pulse, thus keeping unwanted transient voltages out of the measurement path.

Integrator

4.29 IC2 and associated components form an integrator in a feedback loop which provides an accurate 'earth' reference at the input to IC1 and at the sampler (Q22 source). The output from IC2 is also fed via pin 24 to the probe balance and bias circuit (on the Sweep and Pulse Generator p.c.b., Fig. 7). Any tendency to imbalance in the probe bias due to temperature effects produces a d.c. offset voltage at Q24 output. This is detected by IC2 which applies a correction to hold the correct balance. The precise reference level is preset by R77.

Precision Rectifier

4.30 The sample/hold output at Q26 emitter is balanced about earth. It is the function of the precision rectifier to convert this to a unidirectional (positive going) signal. IC3 and IC4 are high-slew-rate amplifiers and the 2k resistors are mounted in a dual-in-line (d.i.l.) resistor array R110.

Squaring and Averaging Circuit

4.31 The 'mean square' of the sample/hold output is obtained by taking the logarithm of the voltage, doubling it, taking the antilogarithm and averaging. This mathematical process is performed by IC5, IC6, IC7 and IC8 with transistors from the array package IC11 as the logarithmic elements. By incorporating a transistor in the feedback path around amplifiers IC5, 6 and 8 a logarithmic characteristic is obtained. A transistor in the input to IC7 produces an antilog characteristic.

4.32 The first process squares the rectified signal voltage, as follows:-

- (1) The rectified signal at TP12 is fed to IC5 and IC6 in parallel. IC5, with transistor IC11a in the feedback path, produces a logarithmic output at TP13.
- (2) The voltage at TP13 is applied to the base of transistor IC11b which is the logarithmic element for IC6. This causes the output of IC6 (at TP14) to be twice the logarithm of the voltage at TP12.

4.33 The second step is to take the antilogarithm of the voltage at TP14 and average it.

- (1) The voltage at TP14 drives a current into IC7 pin 2 via transistor IC11c which is the antilog element.

- (2) IC7 converts the input current to a voltage output, which by means of the feedback loop of C39 and 100k resistors, is proportional to the average of the square of the voltage at TP12.

4.34 Correct biasing and temperature compensation is applied to the base of IC11c from IC8, with transistor IC11e as the logarithmic element. The circuit is preset by R93.

Square Root and Hold Circuit

4.35 The 'root' of the 'mean square' voltage at IC7 pin 6 is obtained by taking the logarithm, halving it and taking the antilog. This is done by logarithmic amplifier IC12 using transistor IC14a as the logarithmic element. The 'noise cancel' and 'offset adjust' voltages are fed in via R95 and R96 to the input of IC12. Transistor IC14b provides temperature compensation.

4.36 The logarithmic voltage from IC12 is halved by the potential divider R100/R101 and fed to the buffer amplifier IC13, which provides an antilog output via transistor IC14d. Temperature compensation is provided by transistor IC14c. Thus the current feed into IC15 pin 2 is proportional to the r.m.s. voltage from the precision rectifier (TP12). The remaining stages apply the reading hold and provide the drive via the anti-jitter circuit to the meter.

Response Select

4.37 The frequency response of amplifier IC15/IC16 is affected by the presence of C53 in the feedback loop. When the RESPONSE switch is at SLOW the FET Q30 is conducting and therefore bypasses C53. When FAST is selected, a negative voltage via D18 (Fig. 7) is fed to the base of Q30, which turns off and thus inserts series capacitance into the loop, which increases the frequency response.

Reading Hold

4.38 Depressing the Hold button on the probe applies on earth to the base of transistor IC14e which turns off FET Q28. The voltage on capacitor C52 is held and fed to the anti-jitter circuit (Fig. 7) via the buffers Q29 and IC16. The effective hold accuracy is within $\pm 0.5\%$ of reading for a period of at least 3 minutes.

POWER SUPPLY

4.37 The power supply system comprises an a.c. mains input with fuse protection in the line lead and voltage selection by the slide switches S1 and S2 (see Chapter 5, Table 5). The secondary voltage from transformer T1 is fed via terminal strip TS1 and the POWER ON/OFF switch S3 to the bridge rectifier D3.

4.38 The reservoir capacitors C5 and C6 are connected to the rectifier outputs and voltage regulation is carried out by 15V integrated circuit regulators IC1 and IC2, which are connected to the terminal strip. Capacitors C1 to C4 provide filtering. Diodes D1 and D2, in series with the external d.c. supply input, provide reverse polarity protection.

CHAPTER 5

MAINTENANCE

USE OF TEST EQUIPMENT

5.1 The test equipment listed in Table 5 must be connected directly to the instrument under test and used according to the manufacturer's instructions. The tests must be made in the order given, and a satisfactory result obtained before proceeding to the next test.

5.2 The 9301A is a precision measuring instrument. Calibration checks must therefore be carried out using only test equipment of equivalent, or higher, accuracy. An approved range of test equipment is listed in Table 5 on the following page.

NOTE: The information in this chapter applies to both the 9301 and 9301A except that references to the RESPONSE switch are applicable only to the 9301A. The RESPONSE switch should be in the SLOW position for all tests unless directed otherwise.

REMOVAL OF COVERS

WARNING: DANGEROUS AC VOLTAGES ARE EXPOSED WHEN COVERS ARE REMOVED WITH AC SUPPLY CONNECTED.

- 5.3 (1) Switch the instrument POWER switch to OFF and switch off the a.c. supply at the bench outlet. Unplug the power lead from the rear panel of the instrument. Disconnect the d.c. supply (if fitted).
- (2) Remove the rubber plugs (located near to the rear end) from both side panels of the instrument and slacken, by about two turns, the screws revealed.
- (3) Grip the rear panel assembly and ease it back from the main case to the maximum extent available (about 5 mm).
- (4) The rear edge of either cover can now be lifted and the cover withdrawn outwards and rearwards.
- (5) To replace the covers reverse the above procedure.

NOTE TO MILITARY USERS

5.4 This instrument contains electrolytic capacitors.

TABLE 5

LIST OF TEST EQUIPMENT REQUIRED

Item	Description	Requirements	Preferred Type
1	Digital Multimeter fitted with filter*	Range 0 to 20V, resolution 1 mV on the 1V range. Accuracy $\pm 0.1\%$	
2	UHF Signal Generator	Range, 800 MHz to 2GHz Output, +6 dBm.	Hewlett Packard HP.8614A
3	VHF Signal Generator (AM/FM)	Range, 10 MHz to 1 GHz. Output, 1V r.m.s. Low noise specification.	HP.8640 with Doubler Option
4	40 kHz Signal Source	Output, 1V to 3.2V r.m.s. into 50Ω , with Precision Attenuator capable of providing signal levels accurate to $\pm 0.2\%$.	
5	Oscilloscope	Bandwidth d.c. to 50 MHz. Sensitivity 10mV/cm.	Tektronix 453 or HP.180A
6	Oscilloscope Probe	1:1 ratio	HP.1007B
7	Millivoltmeter (True RMS)	Range 50 mV to 2V r.m.s. Input impedance $100k\Omega$ Freq. range 50 Hz to 1 MHz Accuracy $\pm 0.1\%$	HP.3400A specially calibrated to 0.1% accuracy
8	Power Meter		Racal/Dana 9303
9	Spectrum Analyzer	Range 0-1200 MHz	HP.8554L (RF Section) HP.8552A (IF Section)
10	Tracking Generator	0-1200MHz	HP.8444A
11	SWR Bridge		Wiltron 60N50 with Option 1

*DVM INPUT FILTER

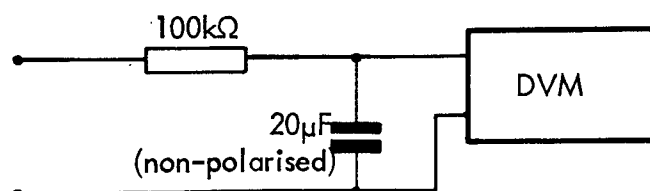

TABLE 5 (continued)

Item	Description	Requirements	Preferred Type
12	Power Supply	240V or 120V, 50 Hz Single phase, line, neutral and earth	
13	LF Signal Generator	Range 10 kHz to 1 MHz	Hewlett Packard 651B
			<u>Quantity</u>
14	Type 'N' to BNC Adaptor		1
15	Type 'N' (male) to G. R. Adaptor		1
16	Type 'N' (female) to G.R. Adaptor		2
17	Length of RG213U Cable with male type N connectors		2 x 1 metre approx.
18	Racal 'Tee' Adaptor Jig T.1 Racal-Dana Part No. 11-1467		1
19	Modified Isolator Body Racal-Dana Part No. 11-1468		1
20	Modified 20dB Attenuator Body Racal-Dana Part No. 11-1469		1
21	Modified 40 dB Attenuator Body Racal-Dana Part No. 11-1470		
22	6 dB Type 'N' Coaxial Attenuator (with VSWR less than 1.1/1)		2
23	50Ω Load, Type 'N' male with VSWR better than 1.05		1
24	Adaptor, Type 'N' female to Type 'N' female		1

POWER SUPPLY CHECKS

Fuse Check

5.5 Check that the rear panel fuse has the correct value, as marked on the rear panel.

Voltage Selection

5.6 Supply voltage selection is by two rear panel slide switches with locking plate.
Proceed as follows:

- (1) Do not connect the a.c. supply.

- (2) On the rear panel extract the two screws securing the cut-away locking plate and remove the plate.
- (3) Connect the multimeter (set to the 'OHMS' range) to the 'line' and 'neutral' pins of the rear panel POWER connector.
- (4) Set the voltage selector slide switches to the positions in Table 6, and check the appropriate transformer resistance at each selection.

TABLE 6

Supply Voltage Selection Switches

Switch Settings		Instrument Voltage Range For Local AC Supply	Resistance Readings (para. 5.6)
* Left Hand Switch	Right Hand Switch		
Down	Up	94V to 110V	59 to 75Ω
Up	Up	110V to 130V	67 to 87Ω
Down	Down	188V to 220V	119 to 265Ω
Up	Down	220V to 260V	233 to 311Ω

* Left hand and right hand are as seen when viewing the rear of the instrument.

- (5) Disconnect the multimeter and set the switches to the local supply voltage (Table 6).
- (6) Ease the plate over the slide switches so the screw holes are aligned. Secure the plate with the two screws previously removed.
- (7) Verify that the cut-away in the plate allows the required voltage range marking to be seen.
- (8) With covers removed (para. 5.3) check that the d.c. resistance to chassis is not less than 30Ω at the following points (if using AVO multimeter connect black lead to positive side of supply line):-
 - (a) + 15V rail at pin 16 on PCB 19-0823.

(b) -15V rail at pin 17 on PCB 19-0823.

PCB 19-0823 is on the underside of the instrument.

- (9) Plug in the a.c. supply.
- (10) Set the POWER switch to ON. Verify that the Power indicator lights.
- (11) Using the digital multimeter check the following voltages at the tag strip on the inner face of the rear panel:-

Pin 3	+15V \pm 0.6V
Pin 6	-15V \pm 0.6V

CALIBRATION

Probe Check

- 5.7 Before proceeding with the tests it is desirable that the probe be checked by use with another 9301 instrument.

Sweep Generator Checks

5.8 Equipment Required

Page 5-2 Table 5

Oscilloscope

Item 5

- (1) The following tests are made on PCB 19-0823 which is located on the underside of the instrument. The p.c.b. layout diagram is Fig. 6, the circuit Fig. 7 and circuit descriptions are in paras. 4.6 to 4.8.
- (2) With the oscilloscope verify a waveform on test point TP2, as shown diagrammatically in Fig. 5.1.
- (3) Transfer the oscilloscope to test point TP3.
- (4) Select -ve trigger and 20 μ s/div timebase. Verify a sawtooth waveform which has a period which varies from 40 μ s to 80 μ s at a 10 Hz rate, as shown diagrammatically in Fig. 5.2.

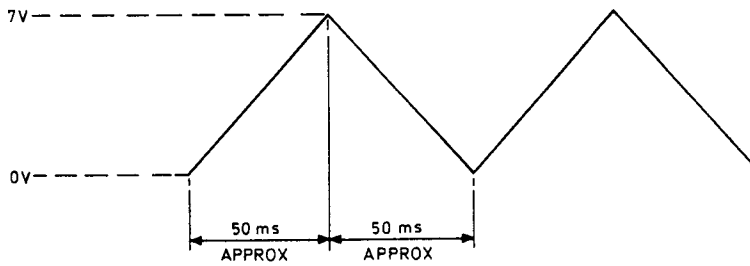

Test Waveform TP2 : 19-0823

Fig.5.1

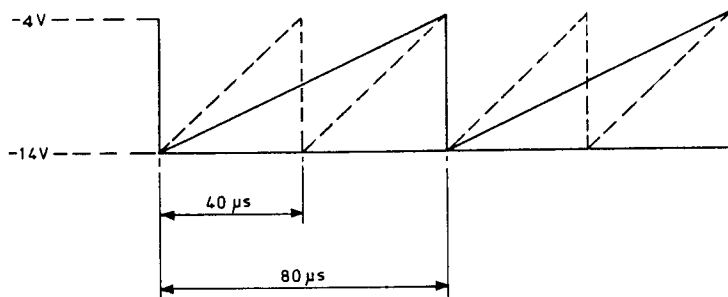

Test Waveform TP3 : 19-0823

Fig.5.2

- (5) Set the POWER switch to OFF and link pins 1 and 2 on 19-0823.
- (6) Switch POWER on, and with the oscilloscope verify a stationary sawtooth waveform on TP3, with a period of $40\mu\text{s} \pm 5\mu\text{s}$.
- (7) On pin 3 verify pulses extending from $-12\text{V} \pm 0.5\text{V}$ to $+6\text{V} \pm 0.5\text{V}$.
- (8) On pin 5 verify pulses extending from $+5\text{V} \pm 0.5\text{V}$ to $-0.7\text{V} \pm 0.1\text{V}$.
- (9) On pin 10 verify pulses extending from $+0.7\text{V} \pm 0.5\text{V}$ to $-15\text{V} \pm 1\text{V}$.
- (10) Retain the link on pins 1 and 2 for the next test.

Probe Balancing

5.9 Equipment Required

Page 5-2 Table 5

Oscilloscope with 1:1 Probe

Items 5 and 6

- 5.10 (1) The following tests involve the PCB's 19-0822 and 19-0823 simultaneously. The relevant diagrams are Figs. 6 to 9.
- (2) Insert the 9301 Probe into the front panel 50 Ω receptacle. Check that pins 1 and 2 on 19-0823 are linked.
- (3) Set the 9301 Range control to the 3V position.
- (4) Set the oscilloscope amplitude to 50mV/div.
- (5) Using the 1:1 probe, connect the oscilloscope to test point TP8 on PCB 19-0822. If necessary, adjust R77 on 19-0822 to obtain the correct waveform, shown diagrammatically in Fig. 5.3.

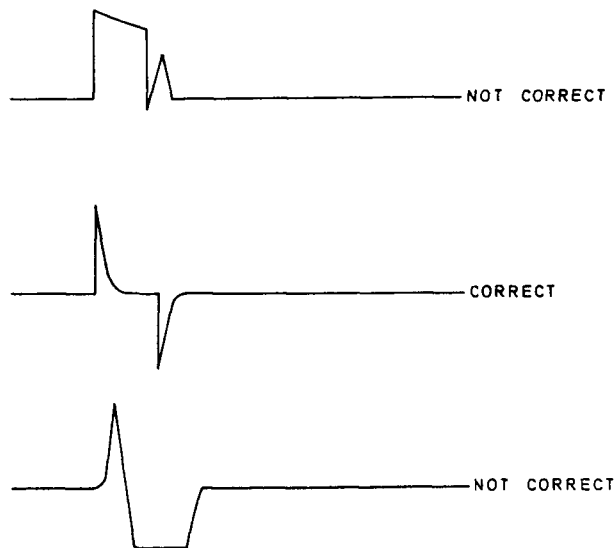

Test Waveform TP8 : 19-0822

Fig 5.3

- (6) Connect a multimeter across pins 12 and 13 on 19-0823 and adjust R47 for $11V \pm 0.25V$.
- (7) Change the oscilloscope to $5mV/div.$, and on PCB 19-0823 link test point TP6 to chassis.
- (8) Using the oscilloscope and 1:1 probe, monitor pin 4 on 19-0822 and adjust R44 on 19-0823 to minimise the waveform shown in Fig. 5.4.

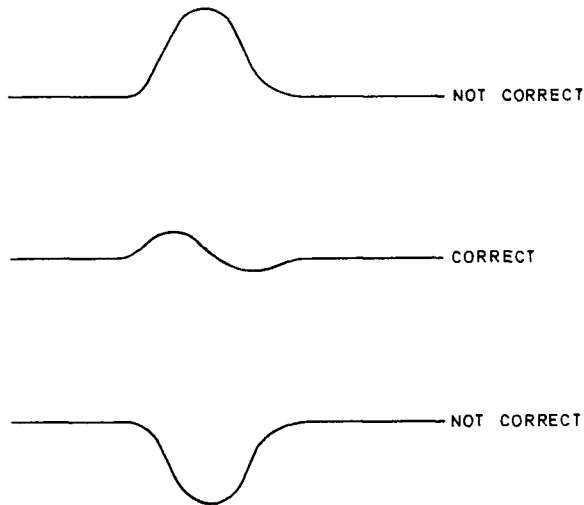

Test Waveform Pin 4 : 19-0822

Fig.5.4

- (9) On 19-0823 remove the shorting link from TP6 and adjust R35 to give a $4mV$ peak, negative-going, pulse, as in Fig. 5.5.
- (10) Finally, remove the link from pins 1 and 2 on 19-0823.

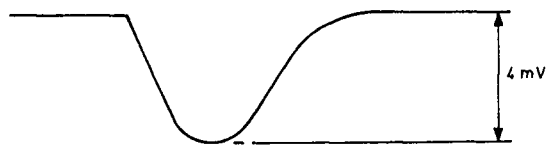

Test Waveform Pin 4 : 19-0822

Fig.5.5

Setting-Up the RMS Circuits

5.11 Equipment Required

Page 5-2 Table 5

Digital Voltmeter (DVM)	Item 1
40 kHz Signal Generator and Precision Attenuator	Item 4
Oscilloscope and 1:1 Probe	Items 5 & 6
True RMS Millivoltmeter	Item 7
Type 'N' to BNC Adaptor	Item 14

NOTE: If an attenuator capable of setting the signal level to $\pm 0.2\%$ over the range 0.3mV to 3.2V r.m.s. is not available, the RMS, Attenuator and Range calibration procedures should not be attempted.

- 5.12 (1) Set the front panel RESPONSE switch to SLOW.
- (2) On PCB 19-0822 disconnect the 'Offset Adjust' lead from pin 16, and remove the link from between pins 17 and 18.
- (3) Connect the 40 kHz signal generator, via the precision attenuator, to the 50 Ω input of the 9301 under test. Insert the 9301 Probe in the front panel receptacle.
- (4) Adjust the Precision Attenuator to provide 1V r.m.s. ± 2 mV into the 50 Ω input of the 9301. (See Fig 5.6).

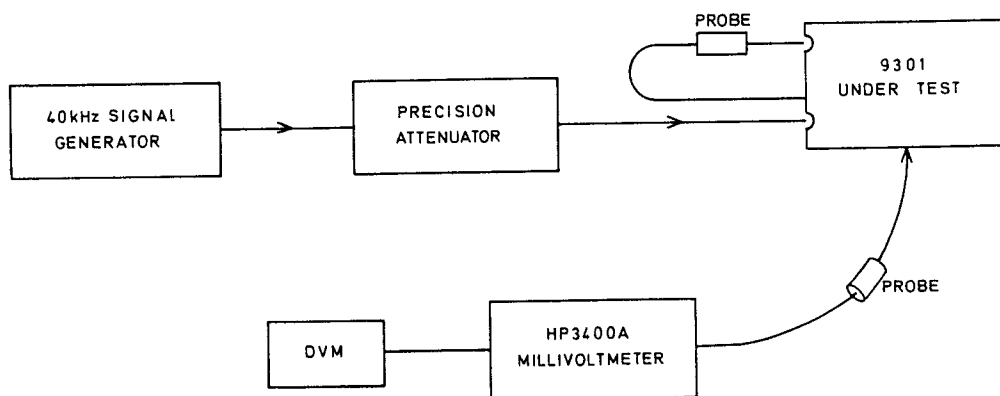

RMS Check Connections

Fig. 5.6

- (5) Set the 9301 Range control to the '1V' position. Set the digital multimeter (DVM) range to read 1V and connect it to the HP3400A. (Fig. 5.6.)
- (6) Using the 1:1 Probe on the HP 3400A, monitor test point TP8 on PCB 19-0822. If necessary adjust R67 on the p.c.b. (see Fig. 8) for a mean 1V on the DVM (the level will be jittering).
- (7) Disconnect the DVM from the millivoltmeter and use it to monitor TP16 on 19-0822. If necessary, adjust R93 (the squarer adjustment) for a reading of $3V \pm 10mV$ on the DVM.
- (8) Transfer the DVM to pin 19 and (if necessary) adjust R99 (the square root adjustment) for a reading of $7.4V \pm 20mV$ on the DVM.
- (9) On PCB 19-0823 (Fig. 6) adjust R69 (meter setting) to give a full scale 1V reading on the 9301 meter.
- (10) Remove the 9301 probe from its receptacle and then re-insert it and verify that the meter takes between 2 and 3 seconds to reach f.s.d.
- (11) Select FAST response on the front panel switch and repeat (10), checking that the meter now reaches f.s.d. in less than 0.8 seconds. Reset the RESPONSE switch to SLOW. (9301A only).
- (12) On PCB 19-0822 refit the link between pins 17 and 18 and reconnect the 'Offset Adjust' lead to pin 16.
- (13) Reduce the 40 kHz signal input level to $316.2mV$ and, again monitoring pin 19 on 19-0822 with the DVM adjust R71 on PCB 19-0823 (Offset adjustment) for a reading of $2.37V \pm 10mV$.
- (14) Maintain the 40 kHz signal source and attenuator connections for the next test.

Attenuator Check

5.13 Equipment Required

As listed in 5.11

- 5.14 (1) Connect the 40 kHz signal generator and precision attenuator as in Fig. 5.6.
- (2) Connect the DVM to the 9301 rear panel DC OUTPUT socket, and using appropriate voltage monitoring, apply the input levels listed in Table 7. (column 1). These input levels must be accurate to within $\pm 0.2\%$.

- (3) Referring to Table 7 select the corresponding Range switch positions (column 2) and adjust the appropriate potentiometer on PCB 19-0822 (column 3) to obtain the DVM reading in column 4. (The DVM reading will be varying slightly. The average figure should be set to that in column 4.)

TABLE 7

Attenuator Check

1	2	3	4
Input Level ($\pm 0.2\%$)	9301 Range Switch Setting	Potentiometer To Adjust on 19-0822	Required 9301 DC Output Reading
1 mV	1 mV	R67	1.000 V
3.16 mV	3 mV	R48	1.000 V
10 mV	10 mV	R20	1.00 V
100 mV	100 mV	R34	1.000 V

- (4) Connect the oscilloscope Y input to TP3 of 19-0822 and the trigger input to pin 20. Set the oscilloscope to External Trigger.
- (5) Set the UUT to the 0 dBm range, and apply 100 mV from the 40 kHz signal generator.
- (6) Adjust R13 in 19-0823 until the pip is at the peak of the observed waveform as in Fig. 5.6.a.

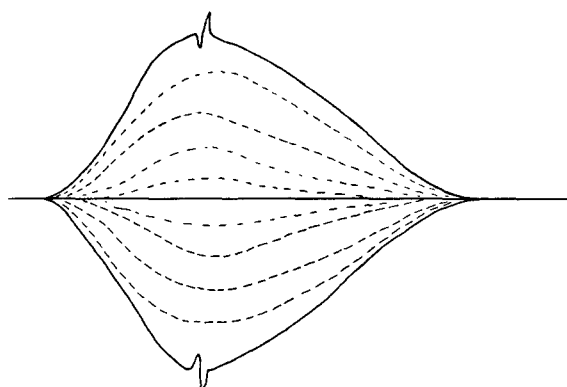

Test Waveform TP3:19-0822 Fig.5.6a

Frequency Response (Probe)

- | <u>5.15</u> | <u>Equipment Required</u> | <u>Page 5-2 Table 5</u> |
|-------------|---------------------------|-------------------------|
| | Digital Voltmeter | Item 1 |
| | UHF Signal Generator | Item 2 |
| | VHF Signal Generator | Item 3 |
| | Oscilloscope and probe | Items 5 and 6 |
| | Power Meter | Item 8 |
| | Cable | Item 17 |
| | Racal Tee Adaptor | Item 18 |
- 5.16 Connect the test equipment as shown in Fig. 5.7.
- 5.17 (1) Set the UUT to the 0 dBm range. Set the signal generator output to 32 MHz at a level which gives an average reading of 707 mV on the DVM. Adjust the power meter calibration adjustment to obtain a power meter reading which is convenient for use as a reference level.
- (2) Set the signal generator output to 250 MHz. Adjust the output level until the power meter indicates the reference level set in (1). The DVM reading should now be between 693 mV and 721 mV.
- (3) Repeat the test given in (2) for a frequency of 500 MHz.
- 5.18 If necessary repeat the tests given in paragraph 5.17, adjusting R47 on the Pulse and Sweep Generator Assembly (19-0823) until the frequency response is within the given limits at the two specified frequencies. If R47 is to be adjusted, monitor pin 4 on the Processor Assembly (19-0822), and adjust R35 on the Pulse and Sweep Generator Assembly (19-0823) to maintain a symmetrical tear drop waveform (Fig. 5.7a).
- 5.19 After adjustment of R47 and R35 ensure that the probe bias rails (module pins 18 and 19) are both at a potential greater than 4.5 volts with respect to earth.
- NOTE: If the frequency response cannot be brought into specification with both probe bias rails at a voltage greater than 4.5V by the procedure given in paragraphs 5.17 to 5.19, change R33 on assembly 19-0823.

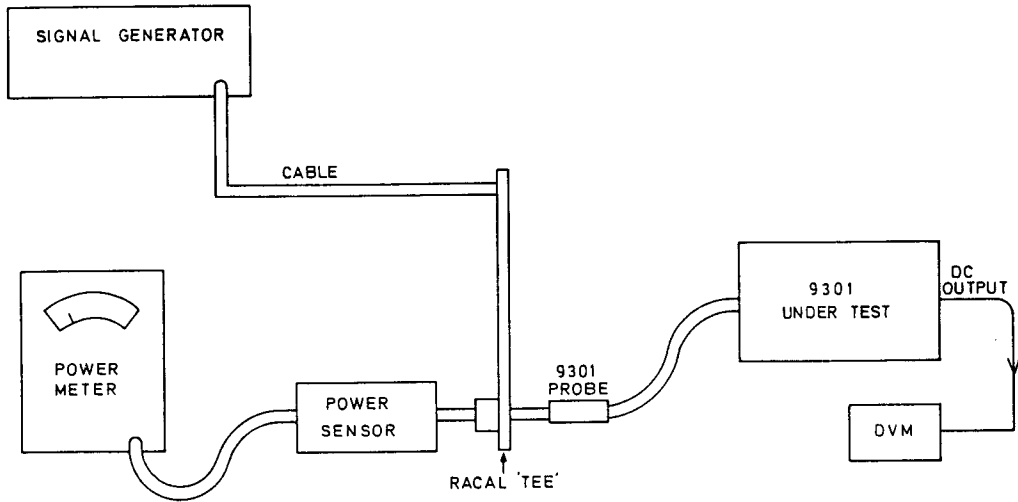

Frequency Response (Probe) Test Connections

Fig.5.7

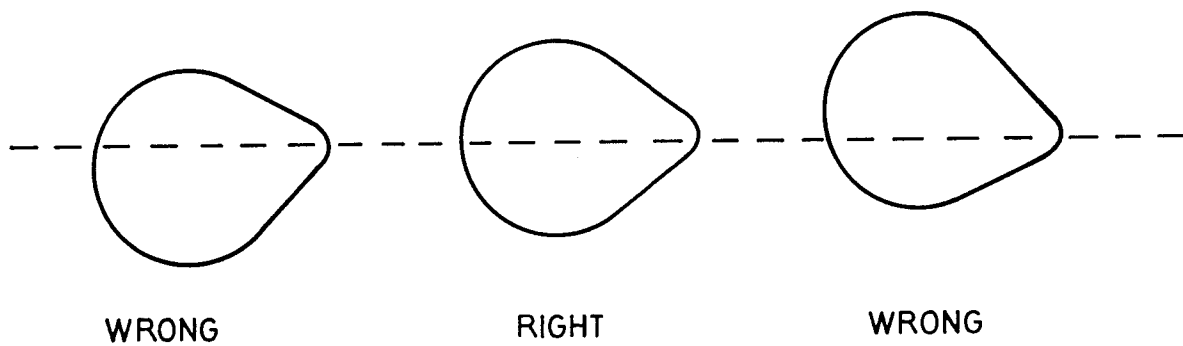

Test Waveforms: Pin 4; 19-0822

Fig.5.7a

Frequency Response (9301 Unit)

5.20 Equipment required

Page 5-2 Table 5

Digital Voltmeter	Item 1
UHF Signal Generator	Item 2
VHF Signal Generator	Item 3
Power Meter	Item 8
Adaptor, Type N male to GR	Item 15
Adaptors, Type N female to GR	Item 16
Cable	Item 17
Coaxial attenuator (6 dB)	Item 22

5.21 Connect the test equipment as shown in Fig. 5.8 with the signal generator output connected to the UUT.

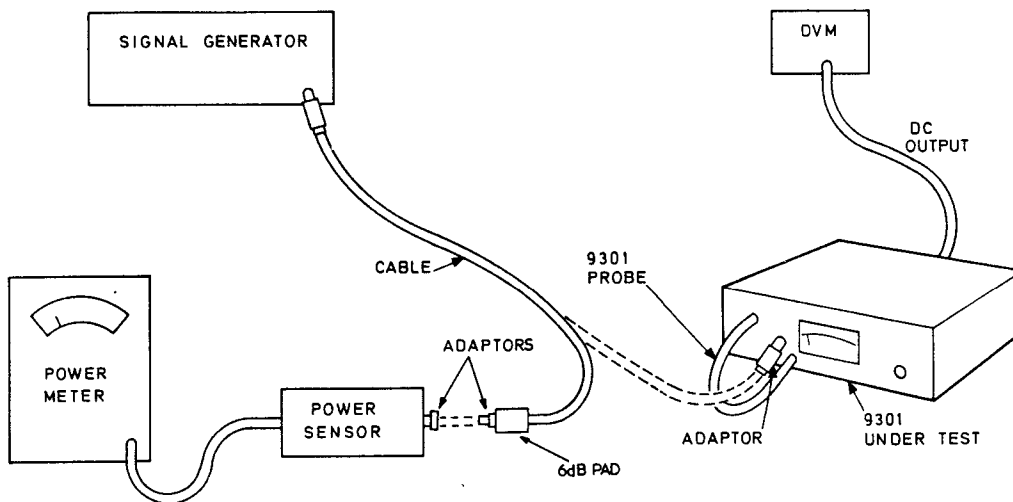

Frequency Response (9301A) Test Connections

Fig.5.8

- 5.22
- (1) Set the UUT to the 0 dBm range. Set the signal generator output to 32 MHz at a level which gives an average reading of 707 mV on the DVM.
 - (2) Transfer the signal generator output to the power sensor. Adjust the power meter calibration adjustment to obtain a power meter reading which is convenient for use as a reference level.
 - (3) Set the signal generator to 500 MHz, and adjust the output level until the power meter indicates the reference level set in (2). Transfer the signal generator output to the UUT and note the DVM reading. Transfer the signal generator output to the power sensor.

- (4) Repeat the test given in (3) for frequencies of 750 MHz, 1 GHz, 1.25 GHz and 1.5 GHz. Note the DVM readings obtained, and check that they are within the limits given in Table 8.

TABLE 8
Frequency Response, 9301A Unit

Input Frequency	DVM Reading	
	A	B
32 MHz	707 mV \pm 1 mV	707 mV \pm 1 mV
500 MHz	697 mV to 717 mV	693 mV to 721 mV
750 MHz to 1.5 GHz	212 mV to 778 mV	212 mV to 778 mV

Use column A for instruments with serial numbers up to and including 2659.
Use column B for all later instruments.

- 5.23 If necessary, repeat the tests given in paragraphs 5.17, 5.18, 5.19, 5.21 and 5.22, adjusting R47 on the Pulse and Sweep Generator Assembly (19-0823) until both the probe and unit frequency responses are within the given limits. Normalise the DVM readings obtained in 5.22 (3) and (4) with respect to the reading obtained at 32 MHz, by dividing by 707, and compare the results with the instrument's calibration curve. If the curve is no longer suitable, or if the instrument is not fitted with a calibration curve, plot the results obtained. The part number of the blank calibration chart is 15-0625 for the 9301A and 15-0769 for the 9302.

Isolator Check

5.24 Equipment Required Page 5-2 Table 5

Digital Voltmeter (DVM)	Item 1
40 kHz Signal Generator and Precision Attenuator	Item 4
True RMS Millivoltmeter	Item 7
Modified Isolator Body	Item 19

5.25 Procedure

- (1) Connect the test equipment as shown in Fig. 5.9.
- (2) Remove the isolator p.c.b. from its housing.
- (3) Fit the special modified body over the Isolator p.c.b. and tighten both 1mm screws for correct earthing.
- (4) Insert the 9301 probe (minus the isolator) into 9301 front panel receptacle.

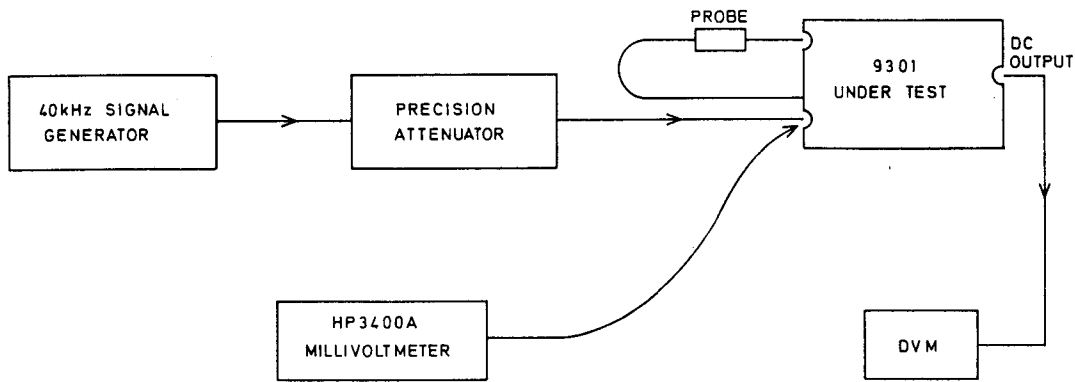

Isolator Check Connections

Fig. 5.9

- (5) Set the 9301 Range switch to the 1 V position.
- (6) Apply a 40 kHz signal at 0.9 V r.m.s. into the 50Ω input of the 9301.
- (7) Note the DVM reading at the 9301 DC OUTPUT socket, as a reference.
- (8) Withdraw the probe, fit the isolator assembly and replace the probe in the front panel receptacle.
- (9) Adjust the isolator trimmer until the reference reading taken at (7) is obtained.

Isolator Frequency Response

5.26 Equipment Required

As listed in para. 5.15 and connected as in Fig. 5.7.

- 5.27 (1) Connect the equipment as in Fig. 5.7 but with the isolator attached to the probe and inserted into the Racal Tee Adaptor.
- (2) Adjust the signal generator output to obtain a reading on the power meter of 0 dBm. Note the DVM reading as a reference.
- (3) While keeping a constant reading of 0 dBm on the power meter, vary the frequency from 20 MHz to 200 MHz and verify that the DVM reading varies by less than 2%. It may be necessary to readjust R47 on 19-0823 to achieve this, in which case the results obtained in paragraphs 5.17, 5.18, 5.19, 5.21 and 5.22 must be rechecked.
- (4) Disconnect the test equipment, and reassemble the isolator in its correct body.

VSWR Check

5.28 Equipment Required

Page 5-2 Table 5

Spectrum Analyser	Item 9
Tracking Generator	Item 10
SWR Bridge	Item 11
Cable	Item 17

5.29 Procedure

- (1) Connect the test equipment as in Fig. 5.10. The 9301 will be connected directly to the 'unknown' port of the SWR Bridge after operation (3).
- (2) Set the Spectrum analyser controls as follows:-

Centre Freq.	500 MHz
Scan Width	100 MHz/div.
Scan Time	5 m/s div.
Video Filter	Off
Bandwidth	300 kHz
Input Atten	10 dB

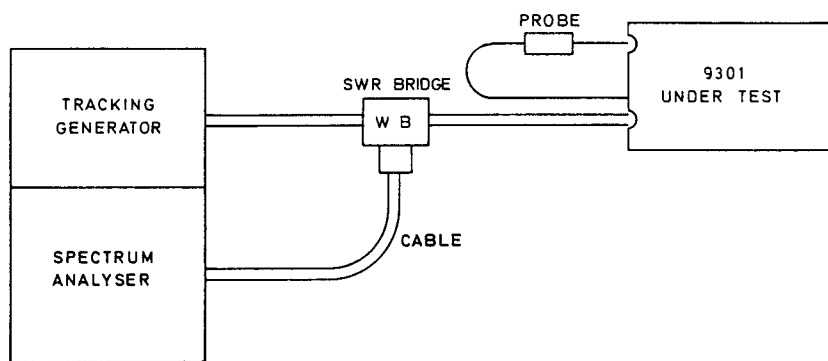

VSWR Test Connections

Fig.5.10

- (3) With 9301 disconnected adjust the LOG REF. control on the analyser to bring the trace to 1 cm below the top of the graticule.
- (4) Connect the 9301 50Ω INPUT socket to the 'unknown' port of the SWR Bridge
- (5) Switch on and check that no part of the trace on the analyser is above the -36 dB line on the graticule up to 800 MHz or above the -30 dB line between 800 MHz and 1 GHz. Adjust the trimmer on 19-0825 to achieve this.

Unit Frequency Response (Recheck)

5.30 Repeat the test in paragraphs 5.20 to 5.22. If the frequency response is no longer within specification it may be necessary to readjust R47 on 19-0823. If this is done it will be necessary to repeat the tests in paragraphs 5.15 to 5.22 and 5.27 until all the frequency responses are within specification.

Range Accuracy Setting Check and Noise Cancel Adjustment

5.31	<u>Equipment Required</u>	<u>Page 5-2 Table 5</u>
	Digital Voltmeter (DVM)	Item 1
	40 kHz Signal Generator	Item 4
	True RMS Millivoltmeter	Item 7

NOTE: The precision attenuator must be capable of setting the input signal levels to an accuracy of $\pm 0.2\%$, otherwise the test should not be attempted.

- 5.32 (1) Connect the test equipment as shown in Fig. 5.9
- (2) Refer to Table 9. Select the required 9301 range and apply the appropriate input level.
- (3) Check the readings obtained. If necessary adjust the nominated resistor to obtain the correct reading.
- (4) With a full scale reading operate the probe push button, withdraw the probe and ensure reading is unaltered. Reinsert probe.

TABLE 9
Range Accuracy Checks

U. U. T. RANGE	INPUT LEVEL	ADJUST	D. V. M. READING X = 1V \pm 1% Y = 0.316V \pm 3%
100mV	100mV	R67 (0822)	X
300mV	316mV	R48 (0822)	X
1 V	1 V	R20 (0822)	X
30mV	31.6mV	R67 (0822)	X
100mV	100mV	R34 (0822)	X
If necessary, adjust R69 on 0823 to give f.s.d. on UUT meter			
1mV	1mV	R88c (0823)	X
3mV	3.16mV	R88a (0823)	X
10mV	10mV	R88d (0823)	X
3 V	3.16V	R88b (0823)	X
10mV	No I/P	R71 (0823)	< 5mV
1mV	.316mV	SET ZERO (Front Panel)	Y
3mV	1mV	R58 (0823)	Y
10mV	3.16mV		Y
30mV	10mV		Y
100mV	31.6mV		Y
300mV	100mV		Y
1 V	316mV		Y
3 V	1V		Y

Scale Linearity Check

5.33 Equipment Required

As listed in para. 5.31 and connected as in Fig. 5.9.

5.34 Procedure

- (1) Set the 9301 Range switch to the 3 V position.
- (2) Apply a precise 3.162 V r.m.s. input to the 9301.
- (3) Using the precision attenuator reduce the signal input level in steps of 10% while checking that the DVM readings at the DC OUTPUT socket are within the tolerances listed in Table 10.
- (4) Set the 9301 Range switch to the 1 mV position and apply a precise 1 mV input to the 9301.
- (5) Repeat test (3).
- (6) Disconnect all test equipment and replace the instrument cover.

TABLE 10

Scale Linearity Checks

Input Level Multiplying Factors	DVM Readings at 9301 DC Output
X 1.0	1.00 V \pm 1%
X 0.9	0.9 V \pm 1%
X 0.8	0.8 V \pm 1%
X 0.7	0.7 V \pm 1%
X 0.6	0.6 V \pm 1%
X 0.5	0.5 V \pm 1%
X 0.4	0.4 V \pm 1.5%
X 0.3	0.3 V \pm 3%
X 0.2	0.2 V \pm 5%
X 0.1	0.1 V \pm 10%

NOTE: The meter may show a zero offset, or the readings may become non-linear at the lower end of the scale if the noise cancellation is not correctly adjusted.

Attenuator Test

5.35 Equipment Required

Page 5-2 Table 5

Digital Voltmeter	Item 1
VHF Signal Generator	Item 3
True RMS Millivoltmeter	Item 7
Power Meter and Sensor	Item 8
LF Signal Generator	Item 13
Racal Tee Adaptor	Item 18
Modified 20 dB Attenuator Body	Item 20
Modified 40 dB Attenuator Body	Item 21

5.36 The tests detailed in this section are applicable to both the 20 dB and the 40 dB attenuators. Only the settings of the 9301A in paragraphs 5.36 (4) and 5.37 (3) differ.

- (1) Remove the attenuator board from its normal body, and insert it into the appropriate modified body.
- (2) Connect the VHF signal generator and the power meter and power sensor to the Tee adaptor, as shown in Fig. 5.11. Connect the digital voltmeter to the 9301A DC OUTPUT socket, and the 9301A probe to the Tee Adaptor, not via the attenuator.
- (3) Set the power meter to the 1 mW range and the 9301A to the 300 mV range. Set the signal generator output to 20 MHz at a level which gives an indication of 1 mW (0 dBm) on the power meter. Record the d.c. output of the 9301A as shown on the digital voltmeter.
- (4) Connect the attenuator between the 9301A probe and the Tee adaptor as shown in Fig. 5.11. Check that the power meter still indicates 1 mW. Set the 9301A to the 30 mV range (20 dB attenuator) or 3 mV range (40 dB attenuator).
- (5) Adjust the trimmer on the attenuator until the d.c. output of the 9301A is the same as that recorded in (3).
- (6) Disconnect the attenuator, and replace the attenuator board in the unmodified body. Reconnect the attenuator to the 9301A probe and the Tee adaptor. Apply frequencies of 20 MHz, 100 MHz and 500 MHz at a level of 1 mW, and ensure that the 9301A d.c. output changes by no more than 3%.

5.37 Disconnect the probe from the attenuator and insert it into the 9301A front panel probe socket. Connect the LF signal generator to the 9301A 50 Ω input socket, and carry out the following test:

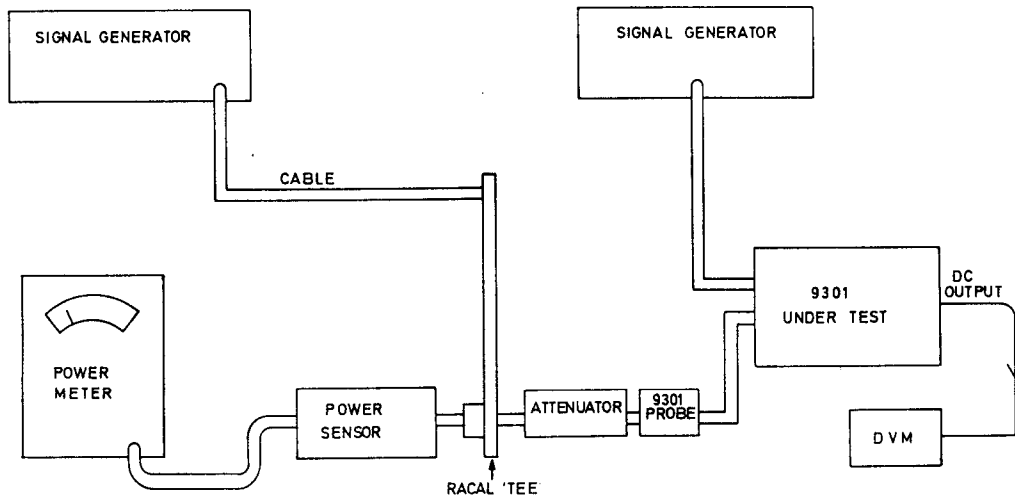

20dB and 40dB Attenuator Test Connections Fig.5.11

- (1) Set the 9301A to the 300 mV range. Set the signal generator output to 1 MHz at a level which gives 0.9 V at the 9301 A d.c. output.
- (2) Remove the probe from the probe socket, fit the attenuator and insert the attenuator in the probe socket.
- (3) Set the 9301A to the 30 mV range (20 dB attenuator) or 3 mV range (40 dB attenuator). Check that the d.c. output is $0.9 \text{ V} \pm 3\%$.

T Piece Tests

VSWR Check

5.38

Equipment Required

Page 5-2 Table 5

Spectrum Analyser
Tracking Generator
SWR Bridge
 50Ω Load

Item 9
Item 10
Item 11
Item 23

The 9301A millivoltmeter with which the T piece is to be used will also be required.

- 5.39 (1) Connect the tracking generator, SWR bridge and spectrum analyser as shown in Fig. 5.12. Leave the third port of the SWR bridge open circuit.

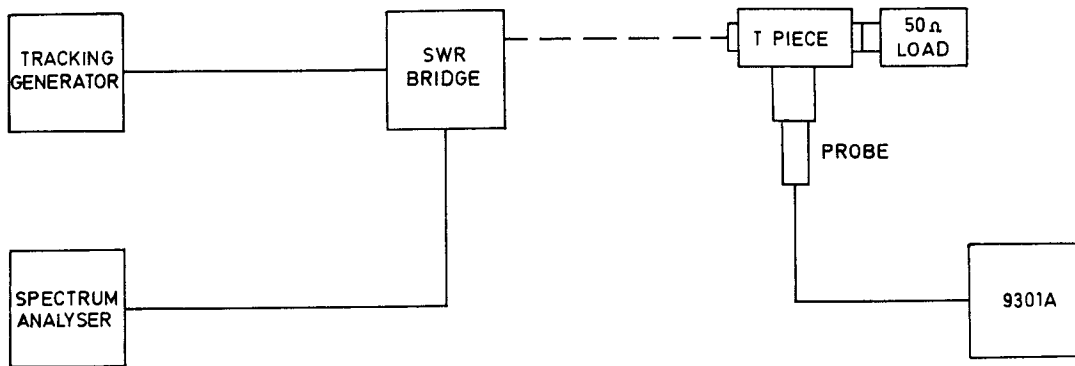

T Piece VSWR Check Connections

Fig.5.12

- (2) Set the spectrum analyser controls as follows:

Centre Frequency	500 MHz
Scan Width	100 MHz/div
Scan time	5ms/div
Video filter	Off
Bandwidth	300 kHz
Input attenuation	10 dB

- (3) After a 10 minute warm up time adjust the tracking generator TRACK ADJUST control to obtain the maximum possible level of displayed trace. Adjust the LOG REFERENCE control to bring the trace to 1 cm below the top of the graticule.
- (4) Connect the T piece to the SWR bridge, and terminate the other end of the T piece with the 50Ω load. Switch on the 9301A and insert the probe into the T piece.
- (5) Check that no part of the level displayed on the spectrum analyser is above the -30 dB level on the graticule.

Insertion Loss

5.40

Equipment Required

Page 5-2 Table 5

UHF Signal Generator
VHF Signal Generator
Power Meter
Cable
6 dB Attenuator
Adaptor

Item 2
Item 3
Item 8
Item 17
Item 22
Item 24

- 5.41 (1) Connect the test equipment as shown in Fig. 5.13. If a Racal Dana 9303 is used as the power meter, ensure that the dummy load is connected to the sampling head.

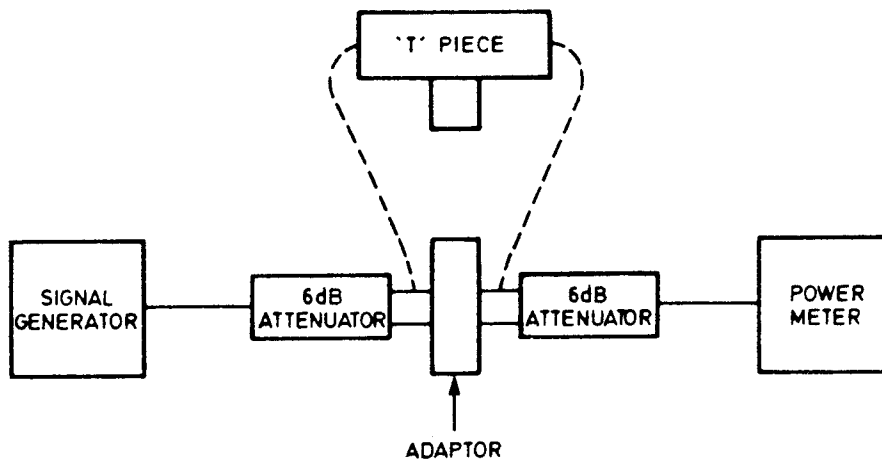

T Piece Insertion Loss Check Connections

Fig.5.13

- (2) Set the signal generator to a frequency of 32 MHz, at a level of 6 dBm.
- (3) Note the reading taken on the power meter, this is the reference level.
- (4) Disconnect the adaptor and connect the T piece in its place. Connect the 9301A, using its probe, to the T piece.
- (5) Note the level reading on the power meter, this should be as shown in Table 11 relative to the reference level taken in (3).
- (6) Check that the 9301A reads 0 dBm +/- 1 dBm.
- (7) Repeat steps (2) to (6) with signal generator frequencies of 500 MHz and 1 GHz.

TABLE 11

Insertion Loss Checks

Frequency	Power Meter Reading w.r.t. Reference Level
32 MHz	0.1 dB to -0.3 dB
500 MHz	0 dB to -0.6 dB
1 GHz	-0.5 dB to -1.5 dB

PROBE REMOVAL

- 5.42 (1) Remove both covers (para. 5.3).
- (2) Release the front panel (para. 5.43) sufficiently to give access to the inner face of the panel.
- (3) Remove the 'P' clip from the inner face of the front panel and release the braid. Remove the 'P' clip from the cast module.
- (4) Unplug the two coaxial plugs from the cast module and unsolder the other four connecting wires, noting the colour code and connection points, as shown in the Overall Block Diagram, Fig.10.
- (5) Push the cable grommet out of the front panel aperture. To do this, carefully compress the 'fingers' of the grommet with a suitable tool, at the same time pushing it outwards.
- (6) Withdraw the probe cable, with plugs attached, through the front panel aperture.

REMOVAL OF FRONT PANEL

- 5.43 (1) Remove the covers (para. 5.3).
- (2) Remove the carrying handle as follows:-
- (a) Insert a suitable tool such as a flat bladed screwdriver into the slot in each boss of the carrying handle and prise off the cap, thus exposing the retaining screws.
 - (b) Extract the screws which hold the carrying handle to the main frame, and remove the handle.
- (3) With the handle removed slide back the short length of coloured metal strip into the space normally occupied by the handle boss. This will allow access to the screws which secure the front panel to the main frame. Remove these screws.
- (4) The front panel assembly can now be carefully withdrawn as far as the wiring permits.
- (5) For further removal, disconnect the interconnecting wiring.

REMOVAL OF REAR PANEL

- 5.44 (1) Completely remove the two screws which are referred to in cover removal (para. 5.3).
- (2) Remove the covers and withdraw the rear panel as far as the wiring permits.
- (3) Unsolder the connections for complete removal of the panel.

PARTS LIST FOR FIG. 3

POWER SUPPLY

NOTE: Except for D3, C5, C6, LP1 and S3, items are mounted on the rear panel assembly.

Part No.	Description	Rat.	Tol %	Value	Component Reference
<u>Resistors</u>					
				<u>Ω</u>	
20-3152	Metal Oxide	½W	5	1 . . 5k	R1
<u>Capacitors</u>					
				<u>F</u>	
21-1551	Ceramic	25V	+80-20	100n	C1, C3, C7, C8
21-1006	Tantalum	35V	20	4.7μ	C2, C4
21-0586	Electrolytic	25V		4700μ	C5, C6
<u>Diodes</u>					
22-1602	Rectifier,	100V, 0.5A			D1, D2
22-1650	Rectifier, bridge	200V, 2A			D3
<u>Integrated Circuits</u>					
22-4208	Regulator,	+15V (MC 7815CP)			IC1
22-4209	Regulator,	-15V (MC 7915CP)			IC2
<u>Switches</u>					
23-4086	Slide, mains selection				S1, S2
23-4043	Power ON/OFF, toggle				S3
<u>Plugs, Sockets and Connectors</u>					
23-3194	Mains plug				PL7
23-3218	Terminals, 2mm, black				SK8, 9, 10
23-3166	Tagstrip, 10-way				TS1
<u>Miscellaneous</u>					
17-4072	Transformer				
23-0033	Fuse (188 - 260V) antisurge 5 x 20 mm			100 mA)	
23-0027	Fuse (94 - 130V) antisurge 5 x 20 mm			200 mA)	FS1
23-0044	Fuseholder for FS1				
26-5003	Indicator, Power on/off, LED, red				LP1
23-3227	Mains Lead Assembly				

PROBE ASSEMBLY PARTS LIST

NOTE: In the event of a Probe fault, customers are strongly advised to return the Probe unit to Racal-Dana, or approved agent, for servicing. Instructions for Probe removal are given on page 5-25. The complete Probe assembly is supplied under Part No.11-0119. Separate parts are listed below:-

Part No.	Description	Rat	Tol %	Value	Component Reference
<u>Miscellaneous</u>					
11-1124	Probe Body Assembly				
14-1459	Probe tip				
15-0428	Cable cover				
16-0382	Protection cap				
25-2019	Multicore connecting cable				
24-7974	Screws c/s M1.6 x 3 mm				

PROBE PCB ASSEMBLY 19-0824 (Fig. 5)

<u>Resistors</u>		<u>W</u>		<u>Ω</u>	
20-5763	Chip	0.125	5	18	R1
20-1551	Carbon Film	0.1	5	100k	R2
20-1561	Carbon Film	0.1	5	1M	R3
20-1521	Carbon Film	0.1	5	1k	R4,R5
20-1542	Carbon Film	0.1	5	4.7k	R6,R7
<u>Capacitors</u>		<u>V</u>		<u>F</u>	
21-1722	Ceramic	100	20	1n	C1
21-1723	Ceramic	100	10	1n	C2,3,4
21-1721	Ceramic	100	10	100p	C5
<u>Diodes and Transistors</u>					
22-1063	Diode Matched Quad, hot carriers (HP 5082. 2815 only)				D1,2,3,4
22-1059	Step Recovery diode, 175 ps (A4S112)				D5
22-6128	Transistor, FET, N-channel (2N5486)				Q1
<u>Miscellaneous</u>					
15-0429	Hold Switch (on Probe body)				S1
17-3210	Transformer				T1
25-4512	Inductor (30 mm wire 0.180 mm)				L1

PROBE ACCESSORIES

Accessories are listed in the Technical Specification

PARTS LIST FOR FIG. 7

PULSE AND SWEEP GENERATOR ASSEMBLY 19-0823

Part No.	Description	Rat.	Tol %	Value	Component Reference	Part No.	Description	Rat.	Tol %	Value	Component Reference
<u>Resistors</u>						<u>Capacitors</u>					
		<u>W</u>		<u>Ω</u>				<u>V</u>		<u>F</u>	
20-2101	Carbon Film	1/4	5	100	R39, 40	21-0632	Elec. Alum	25	-10 +50	10μ	C14, 17
20-2102	Carbon Film	1/4	5	1k	R16, 30	21-0634	Elec. Alum	47	-10 +50	47μ	C2, 13, 16.
20-2103	Carbon Film	1/4	5	10k	R34, 36, 37, 38,	21-1002	Tantalum	20	20	10	C18, 19
20-2104	Carbon Film	1/4	5	100k	R41, 56, 61, 64, 65, 77, 78, 81, 84, 85, 86	21-1015	Tantalum	15	20	3.3μ	C3
20-2105	Carbon Film	1/4	5	1M	R63, 70	21-1045	Tantalum	16	20	47μ	C7, 8, 26, 27
20-2121	Carbon Film	1/4	5	120	R28, 31	21-1519	Ceramic	500	10	82p	C5
20-2122	Carbon Film	1/4	5	1.2k	R29	21-1532	Ceramic	500	20	1n	C1, 9, 10
20-2123	Carbon Film	1/4	5	12k	R24	21-1536	Ceramic	500	25	2.2n	C25
20-2152	Carbon Film	1/4	5	1.5k	R12, 20, 23, 75	21-1545	Ceramic	25	-20+80	10n	C20, 21, 31, 32
20-2153	Carbon Film	1/4	5	15k	R5	21-1547	Ceramic	18	-20+80	33n	C11
20-2184	Carbon Film	1/4	5	180k	R53	21-1551	Ceramic	25	-20+80	100n	C12, 15
*Carbon Film *	1/4	5			R33	21-1616	Ceramic	12	-20+80	100n	C22
20-2221	Carbon Film	1/4	5	220	R60	21-2888	Silver Mica	350	1	825p	C4, 6
20-2222	Carbon Film	1/4	5	2.2k	R10, 15, 48, 83	21-5503	Polycarbonate	100	20	220n	C23, 30
20-2224	Carbon Film	1/4	5	220k	R57, 59	21-5504	Polycarbonate	100	20	330n	C28
20-2272	Carbon Film	1/4	5	2.7k	R27	21-5507	Polycarbonate	100	20	1.0μ	C24, 29
20-2008	Carbon Film	1/4	5	4.7	R82	<u>Diodes</u>					
20-2333	Carbon Film	1/4	5	33k	R2, 3, 50, 79, 80	22-1029	Silicon: general purpose (1N4149)				D1, 5, 6, 7, 8, 9 10, 11, 12, 13, 14, 15, 16, 17, 18, 20, 22, 23, 24
20-2392	Carbon Film	1/4	5	3.9k	R1, 4, 14	22-1807	Voltage regulator (BZY88C4V7)				D3, 21
20-2470	Carbon Film	1/4	5	47	R18, 19	22-1809	Voltage regulator (BZY88C5V6)				D4
20-2472	Carbon Film	1/4	5	4.7k	R7, 11, 43, 45	22-1811	Voltage regulator (BZY88C6V8)				D2
20-2561	Carbon Film	1/4	5	560	R17	22-1803	Voltage regulator (BZY88C3V3)				D19
20-2562	Carbon Film	1/4	5	5.6k	R42, 46	<u>Transistors</u>					
20-2563	Carbon Film	1/4	5	56k	R6	22-6017	Silicon: npn (2N2369)				Q1, 2, 3, 7, 8, 11, 13, 16, 19
20-2681	Carbon Film	1/4	5	680	R25, 26, 72, 73	22-6041	Silicon: npn (BC109)				Q5
20-2682	Carbon Film	1/4	5	6.8k	R9, 68	22-6110	Silicon: pnp (BFX48)				Q4, 9, 10, 12, 14 15, 17
20-2683	Carbon Film	1/4	5	68k	R8, 49, 51, 52, 54, 55	22-6126	Unijunction (2N4870)				Q6
20-3152	Metal Oxide	1/2	5	1.5k	R21	22-6127	MOS FET (U 1898 E)				Q18, 20, 21
20-3471	Metal Oxide	1/2	5	470	R22	<u>Inductors</u>					
20-3681	Metal Oxide	1/2	5	680	R32	23-7056	Coil		10	100μH	L1
20-4893	Metal Oxide	1/2	0.1	1M	R61, 64	<u>Integrated Circuits</u>					
20-4902	Metal Oxide	1/4	0.1	7.5k	R66	22-4111	741				IC1
20-4903	Metal Oxide	1/4	0.1	1.15k	R67	22-4212	308				IC2
20-4993	Metal Film	0.125	1	18k	R91	22-4771	4051				IC3
20-7510	Metal Film	1/4	1	3.83k	R87	22-4229	TL081				IC4
20-7511	Metal Film	1/4	1	15k	R89, 90, 92	<u>Variable Resistors</u>					
* R33 is selected by test. The nominal value is 47Ω (Part No. 20-2470)											
20-7070	Carbon, linear	1/4	20	1k	R35	<u>Variable Resistors</u>					
20-7089	Carbon, linear	1/4	20	2k	R69	<u>Variable Resistors</u>					
20-7075	Carbon, linear	1/4	20	5k	R13, 44	<u>Variable Resistors</u>					
20-7068	Carbon, linear	1/4	20	100k	R58	<u>Variable Resistors</u>					
20-7062	Trimpot			100k	R47, 71	<u>Variable Resistors</u>					
20-7121	Variable	1/4		10K	R88a	<u>Variable Resistors</u>					
20-7121	Variable	1/4		10K	R88b	<u>Variable Resistors</u>					
20-7121	Variable	1/4		10K	R88c	<u>Variable Resistors</u>					
20-7121	Variable	1/4		10K	R88d	<u>Variable Resistors</u>					

PARTS LIST FOR FIG. 9
PROCESSOR ASSEMBLY 19-0822

Part No.	Description	Rat.	Tol %	Value	Component Reference	Part No.	Description	Rat.	Tol %	Value	Component Reference
	<u>Resistors</u>	<u>W</u>		<u>Ω</u>			<u>Capacitors</u>	<u>V</u>		<u>F</u>	
20-2101	Carbon Film	$\frac{1}{4}$	5	100	R3, 9, 55	21-1045	Tantalum	16	20	47 μ	C1, 3, 5
20-2102	Carbon Film	$\frac{1}{4}$	5	1k	R68, 76	21-0626	Electrolytic	16	-10+50	150 μ	C4, 6
20-2103	Carbon Film	$\frac{1}{4}$	5	10k	R1, 17, 30, 44, 49, 57, 63, 73, 103, 106	21-1002	Tantalum	20	20	10 μ	C7, 8, 9, 10, 11, 12, 14, 16, 18, 19, 20, 24, 25
20-2104	Carbon Film	$\frac{1}{4}$	5	100k	R23, 50, 86, 87, 91, 97, 107, 112, 113	21-1029	Tantalum	35	20	1.5 μ	C45
20-2124	Carbon Film	$\frac{1}{4}$	5	120k	R72, 74	21-1041	Tantalum	35	20	1.0 μ	C22, 23, 51
20-2153	Carbon Film	$\frac{1}{4}$	5	15k	R8, 14, 29, 40, 43, 52, 78	21-1049	Tantalum	35	20	220n	C39, 53
20-2154	Carbon Film	$\frac{1}{4}$	5	150k	R109	21-1514	Ceramic	500	10	33p	C36, 37
20-2182	Carbon Film	$\frac{1}{4}$	5	1.8k	R15, 27, 41	21-1530	Ceramic	500	10	680p	C21
20-2183	Carbon Film	$\frac{1}{4}$	5	10k	R95	21-1536	Ceramic	500	25	2.2n	C43, 47, 48, 49
20-2184	Carbon Film	$\frac{1}{4}$	5	180k	R81	21-1545	Ceramic	25	-20+8C	10n	C13, 50
20-2221	Carbon Film	$\frac{1}{4}$	5	220	R66, 105	21-1547	Ceramic	18	-20+80	33n	C26, 27, 29, 30, 32, 33, 34, 35, 40, 41, 42, 44
20-2222	Carbon Film	$\frac{1}{4}$	5	2.2k	R79	21-1616	Ceramic	12	-20+80	100n	C2, 13, 38, 46
20-2223	Carbon Film	$\frac{1}{4}$	5	22k	R7, 22, 36	21-2588	Silver Mica	350	2	1n	C17
20-2224	Carbon Film	$\frac{1}{4}$	5	220k	R37, 102	21-4512	Polyester	100	20	1.0 μ	C52
20-2272	Carbon Film	$\frac{1}{4}$	5	2.7k	R69, 70						
20-2273	Carbon Film	$\frac{1}{4}$	5	27k	R16, 31, 45						
20-2274	Carbon Film	$\frac{1}{4}$	5	270k	R104						
20-2332	Carbon Film	$\frac{1}{4}$	5	3.3k	R64						
20-2334	Carbon Film	$\frac{1}{4}$	5	330k	R90						
20-2391	Carbon Film	$\frac{1}{4}$	5	390	R53						
20-2392	Carbon Film	$\frac{1}{4}$	5	3.9k	R65, 88, 89						
20-2393	Carbon Film	$\frac{1}{4}$	5	39k	R18, 32, 46						
20-2471	Carbon Film	$\frac{1}{4}$	5	470	R4, 5	22-1029	Silicon: general purpose (1N4149)				D1, 2, 3, 4, 5, 6, 7, 9, 10, 11, 12, 13, 14, 16, 18
20-2472	Carbon Film	$\frac{1}{4}$	5	4.7k	R62						
20-2473	Carbon Film	$\frac{1}{4}$	5	47k	R10, 24, 38	22-1803	Voltage regulator			3.3V	D8
20-2474	Carbon Film	$\frac{1}{4}$	5	470k	R96	22-1807	Voltage regulator			4.7V	D17
20-2561	Carbon Film	$\frac{1}{4}$	5	560	R75, 80	22-1818	Voltage regulator			13V	D15
20-2562	Carbon Film	$\frac{1}{4}$	5	5.6k	R2, 12						
20-2563	Carbon Film	$\frac{1}{4}$	5	56k	R6, 71	22-6017	Silicon: npn (2N2369)				Q 6, 12, 18, 21, 25
20-2822	Carbon Film	$\frac{1}{4}$	5	8.2k	R26	22-6038	Silicon: pnp (BCY71)				Q24
20-2823	Carbon Film	$\frac{1}{4}$	5	82k	R98	22-6041	Silicon: npn (BC109)				Q1, 2, 4, 5, 8, 10, 11, 14, 16, 17, 26
20-4787	Metal Film	25ppm	1	8k	R11	22-6101	MOS. FET: 'N' channel (W300A)				Q23
20-4879	Metal Film	$\frac{1}{4}$	2	500	R35	22-6110	Silicon: pnp (BFX48)				Q3, 9, 15, 20, 27
20-4880	Metal Film	$\frac{1}{4}$	1	560	R25, 39	22-6111	MOS. FET: 'N' channel (E108)				Q7, 13, 19
20-4881	Metal Film	$\frac{1}{4}$	1	1k	R54, 94	22-6127	MOS. FET: (U1898E)				Q22, 28, 29, 30
20-4882	Metal Film	$\frac{1}{4}$	$\frac{1}{2}$	1k	R21, 51						
20-4923	Metal Film	$\frac{1}{4}$	$\frac{1}{2}$	2k	R47						
20-4885	Metal Film	$\frac{1}{4}$	1	5.6k	R13, 28, 42						
20-4887	Metal Film	$\frac{1}{4}$	$\frac{1}{2}$	8.87k	R19						
20-4888	Metal Film	$\frac{1}{4}$	1	12k	R92						
20-4889	Metal Film	$\frac{1}{4}$	1	16k	R60						
20-4890	Metal Film	$\frac{1}{4}$	0.1	18k	R100, 101	22-4111	High Performance Op. Amp. (Type 741) IC2, 16				
20-4891	Metal Film	$\frac{1}{4}$	$\frac{1}{2}$	48.7k	R33	22-4297	Internally compensated Op. Amp. (LF355H) IC5, 6, 7				
20-4892	Metal Film	$\frac{1}{4}$	0.1	250k	R108	22-4298	High slew rate Op. Amp. (LF356BN) IC3, 4				
20-5505	DIL Array			2k	R110	22-4212	Low Bias Current Op. Amp. (LM308H) IC8, 12, 13, 15				
20-5504	DIL Array			100k	R111	22-4213	Transistor Array (SL3046) IC11, 14				
						22-4299	(LF357BN) IC1				
	<u>Variable Resistors</u>			<u>Ω</u>							
20-7061	Linear	$\frac{1}{4}$	20	500	R20						
20-7070	Linear	$\frac{1}{4}$	20	1k	R77						
20-7046	Cermet			10k	R93						
20-6544	Linear	$\frac{1}{4}$	20	3.3k	R34						
20-7072	Linear	$\frac{1}{4}$	20	50k	R99						
20-6631		$\frac{1}{4}$	20	330	R48						
20-7063	Cermet			500	R67						

PARTS LIST FOR FIG. 10

Part. No.	Description	Component Reference
-----------	-------------	---------------------

50Ω TERMINATION PCB ASSEMBLY 19-0825

20-4895	Chip Resistor	150 mW 1% 100Ω	R1, R2
21-6037	Capacitor, trimmer	0.3-1.2pF	C1
24-0176	Printed circuit connector jack		SK5
23-3226	'N' Type, panel receptacle		SK6

FRONT PANEL ASSEMBLY (Parts List 11-1114)

20-7041	Potentiometer, 'Set Zero'	50k	R2
17-1004	Meter		M1
23-4043	Switch, toggle (Power)		S3
17-0095	Switch, rotary, b.c.d. (Range)		S4
23-4065	Switch, toggle (Response Select)		S5

REAR PANEL ASSEMBLY

23-3030	Socket, BNC (DC Output)		SK4
23-3215	Connector 9-way (Remote Program)		PL3
23-3214	Connector 9-way (mates with 23-3215)		
NOTE:	Other rear panel items are listed under 'Power Supply' in Parts List 1.		

MODULE ASSEMBLY (Parts List 11-1118)

23-3167	Receptacle, bulkhead (on cast module)		SK21, SK23
21-6502	Capacitors, feed-through (on cast module)		

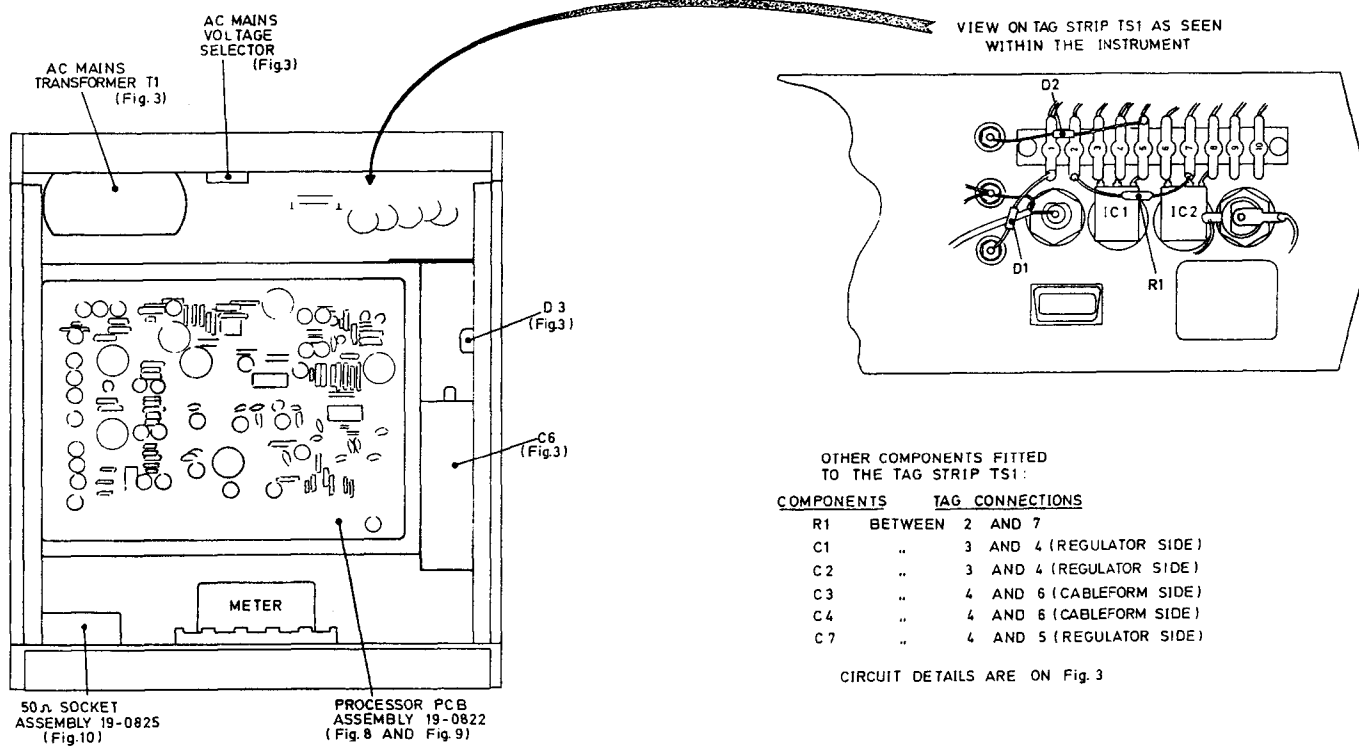

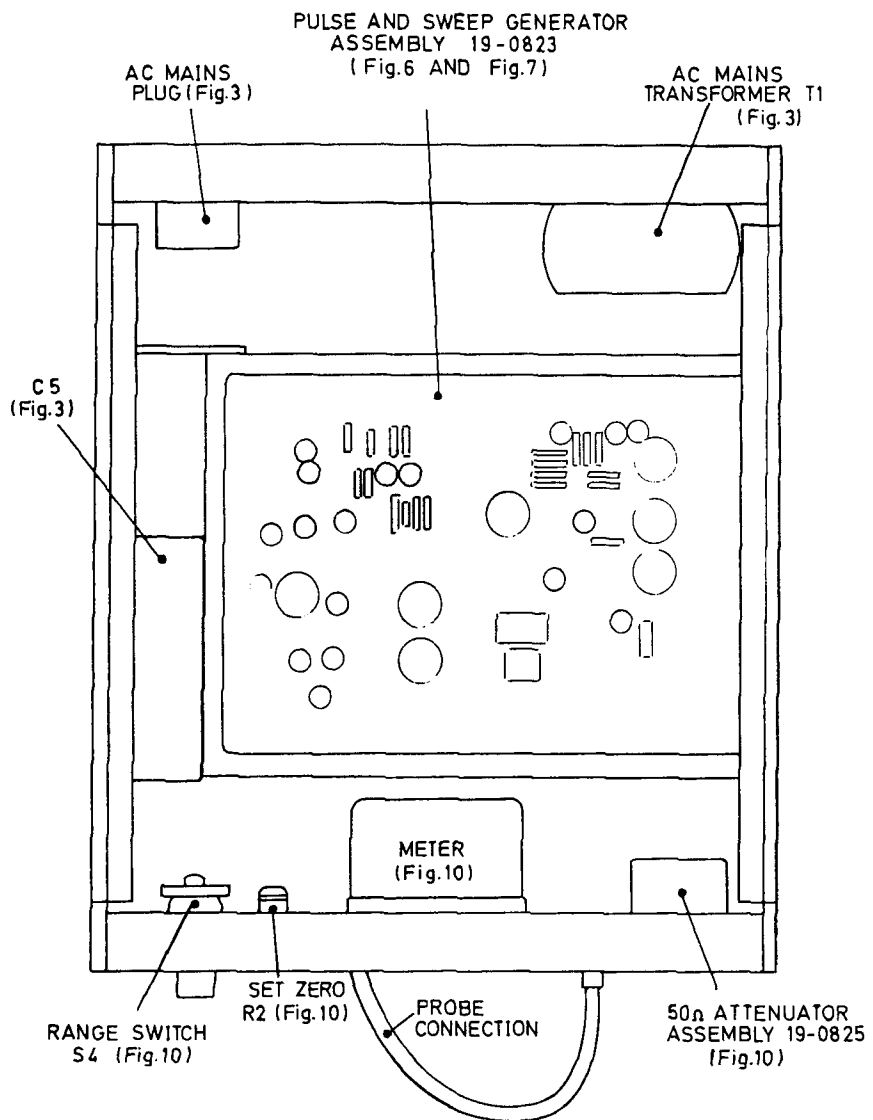

RACAL
 WOH 8166
 A

Chassis Layout: 9301A
 Underside View

Fig. 2

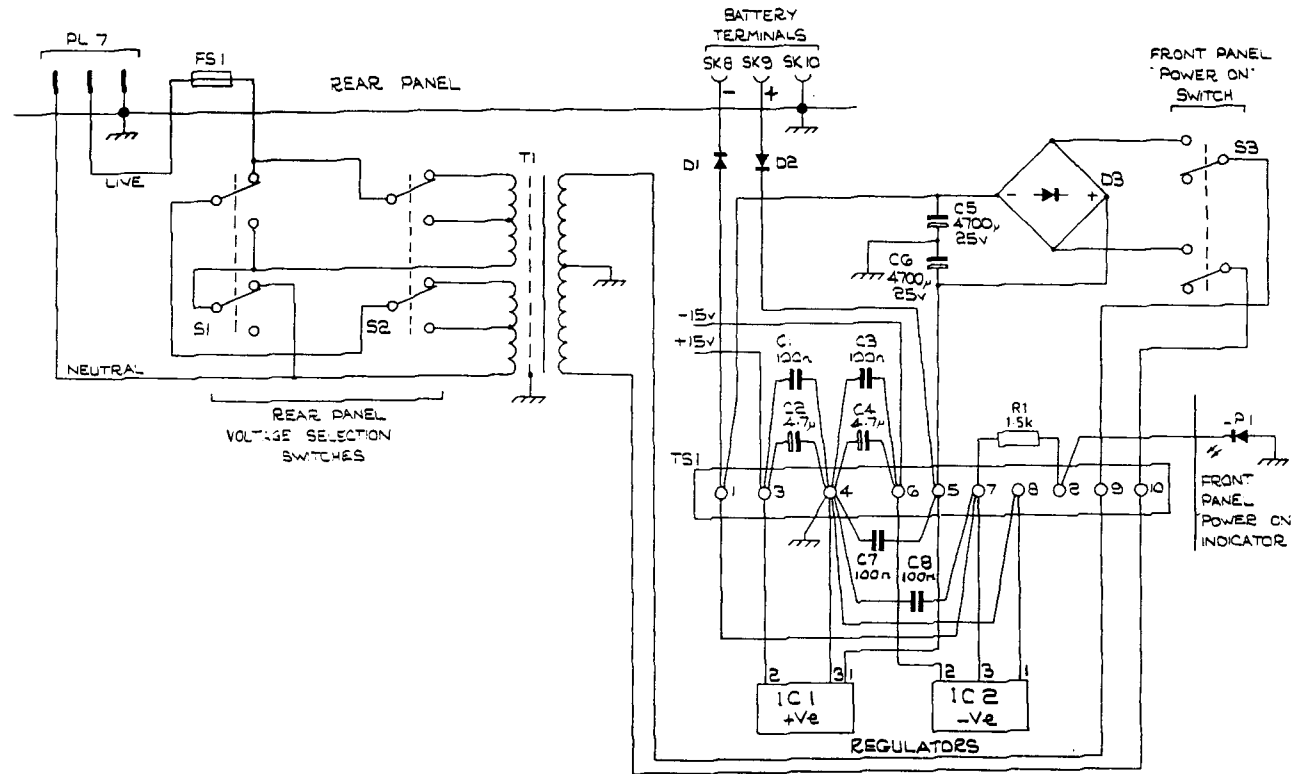

WOH8166 | 9301A SH12
11

Circuit : Power Supply

Fig.3

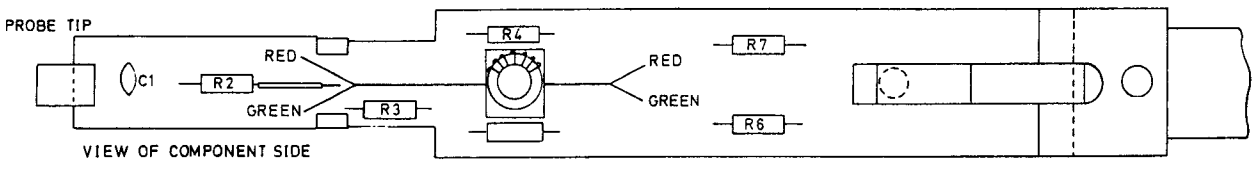
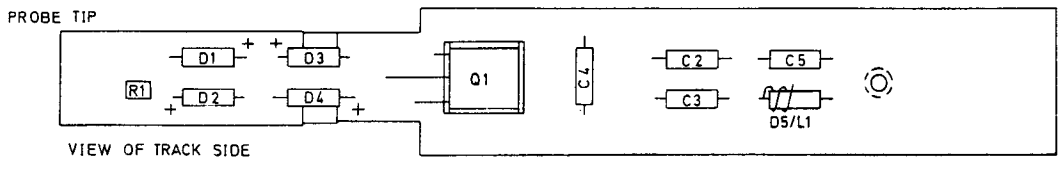

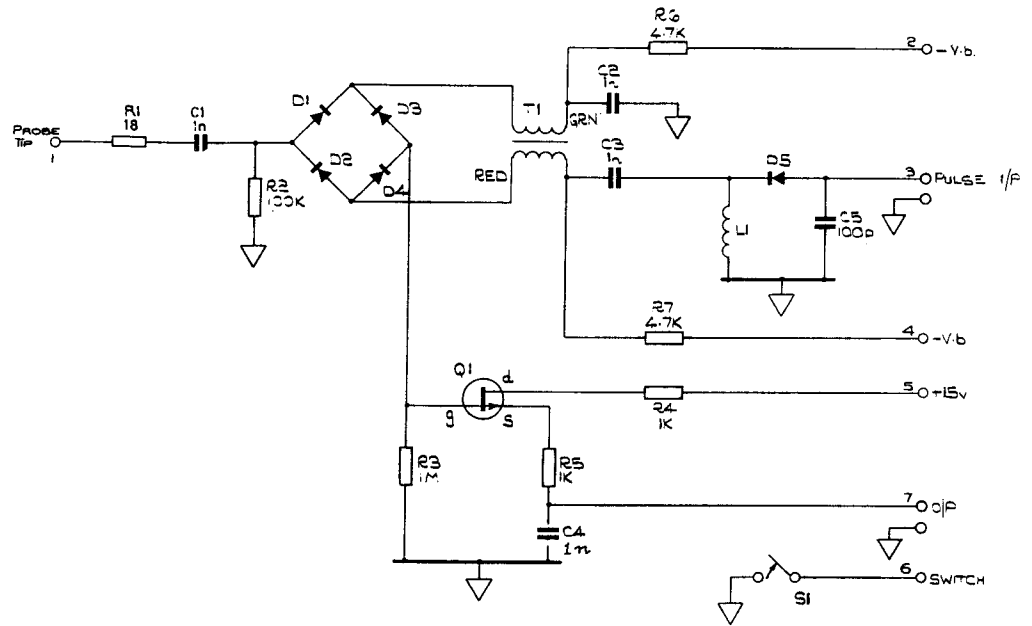

REFERENCE	PART No.	TYP. TYPE No.
D1 - 4	22 - 1063	HP 5082 - 2815
D5	22 - 1059	A49112
Q1	22 - 6128	2N 5486

RACAL
 WGH 8166 19-0824
 1121

Circuit: Probe Assembly 19-0824 Fig. 5

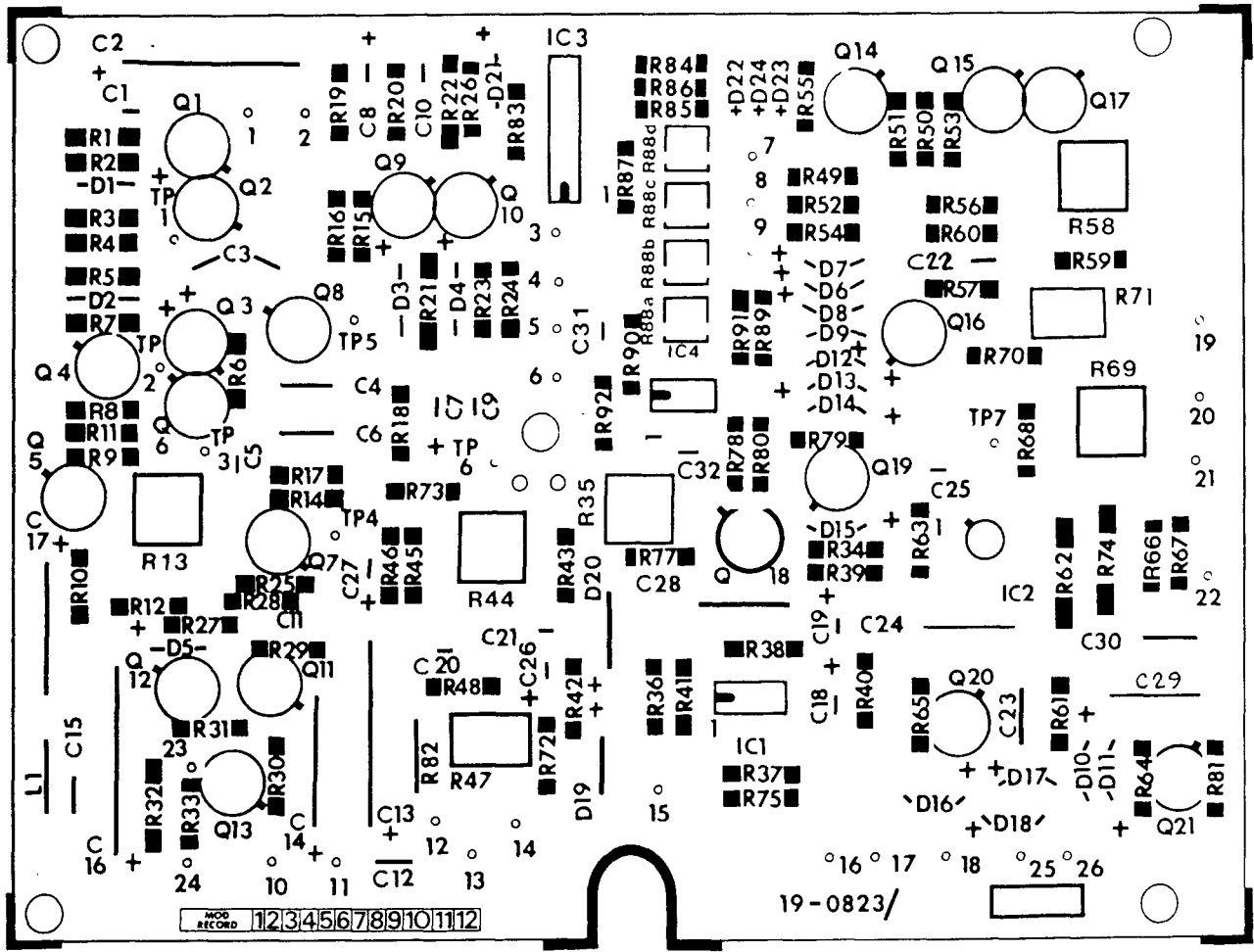

Component Layout: Pulse and Sweep
Generator PCB 19-0823

Fig.6

RACAL
 WOH 816F 9301A
 47 10 11

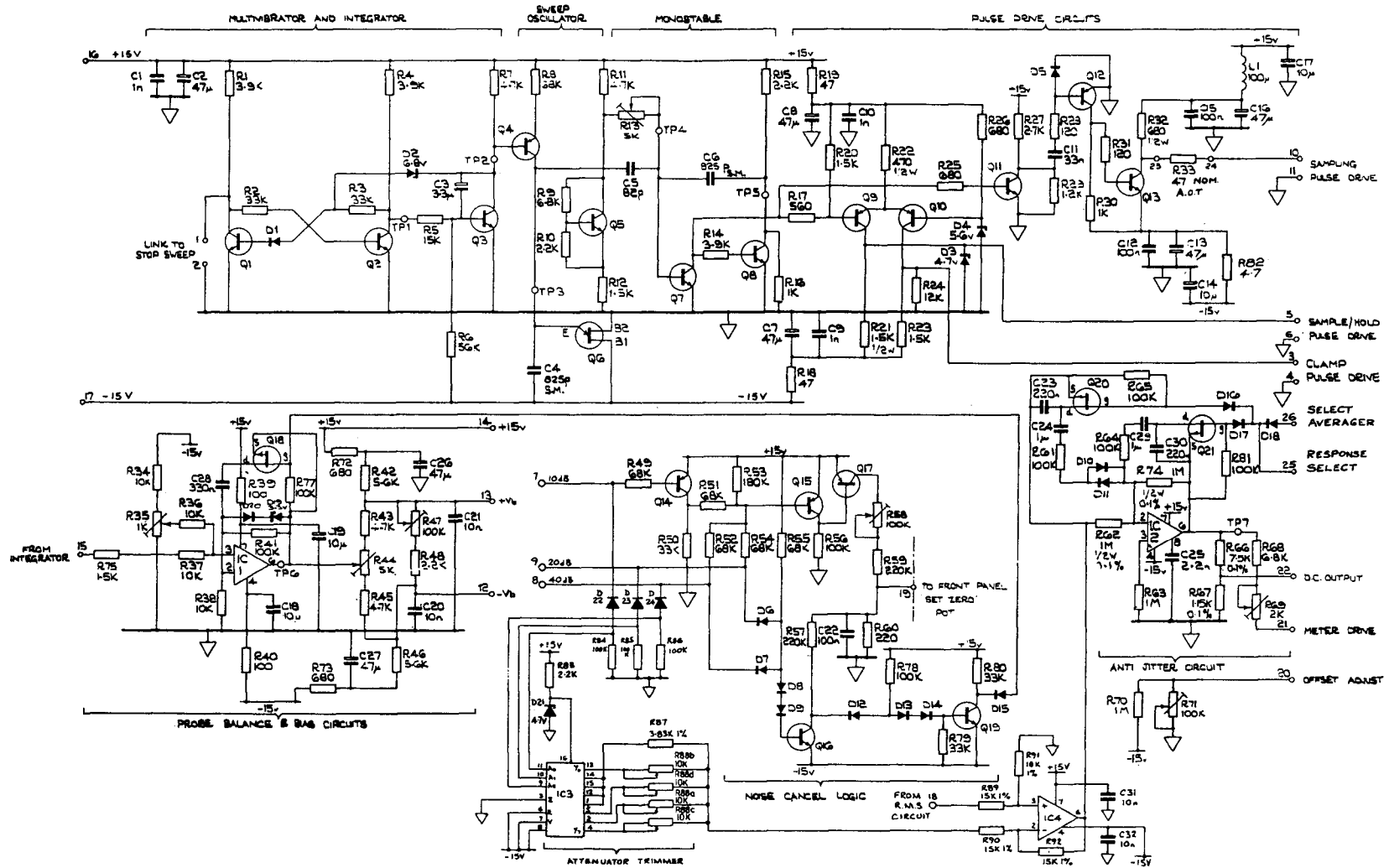

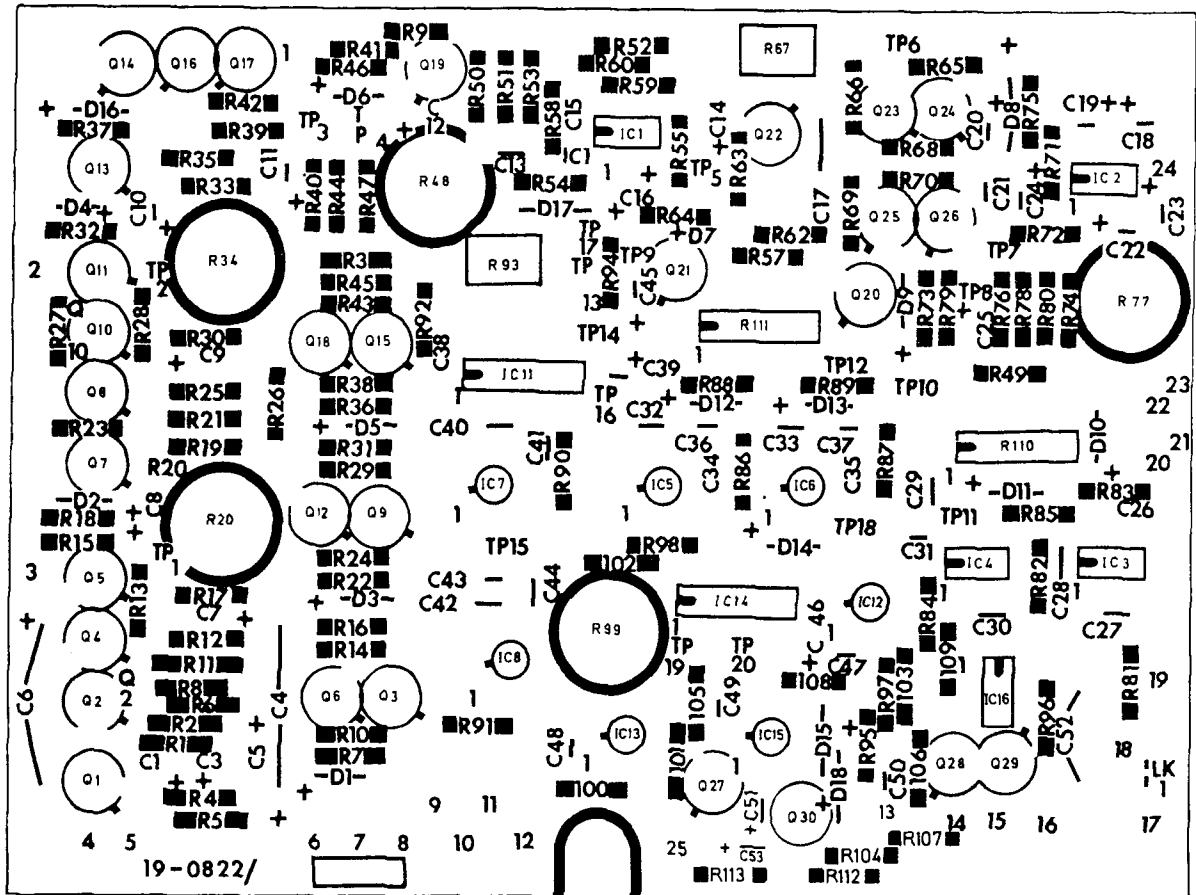

WOH 8166 | 19-0822
1 | 3 | 09

Component Layout: Processor PCB 19-0822

Fig. 8

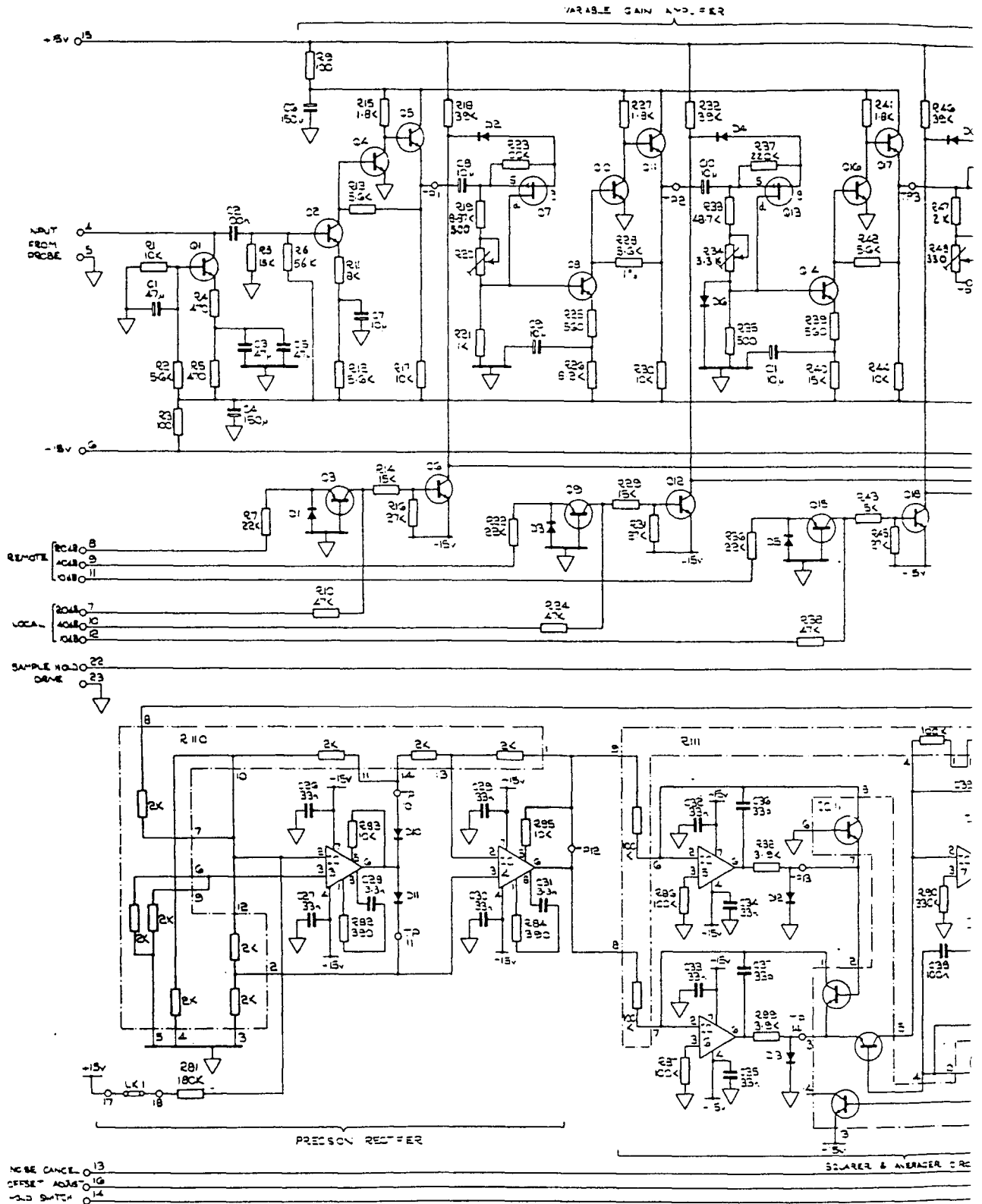

WOH 8166 19-052
 1713158

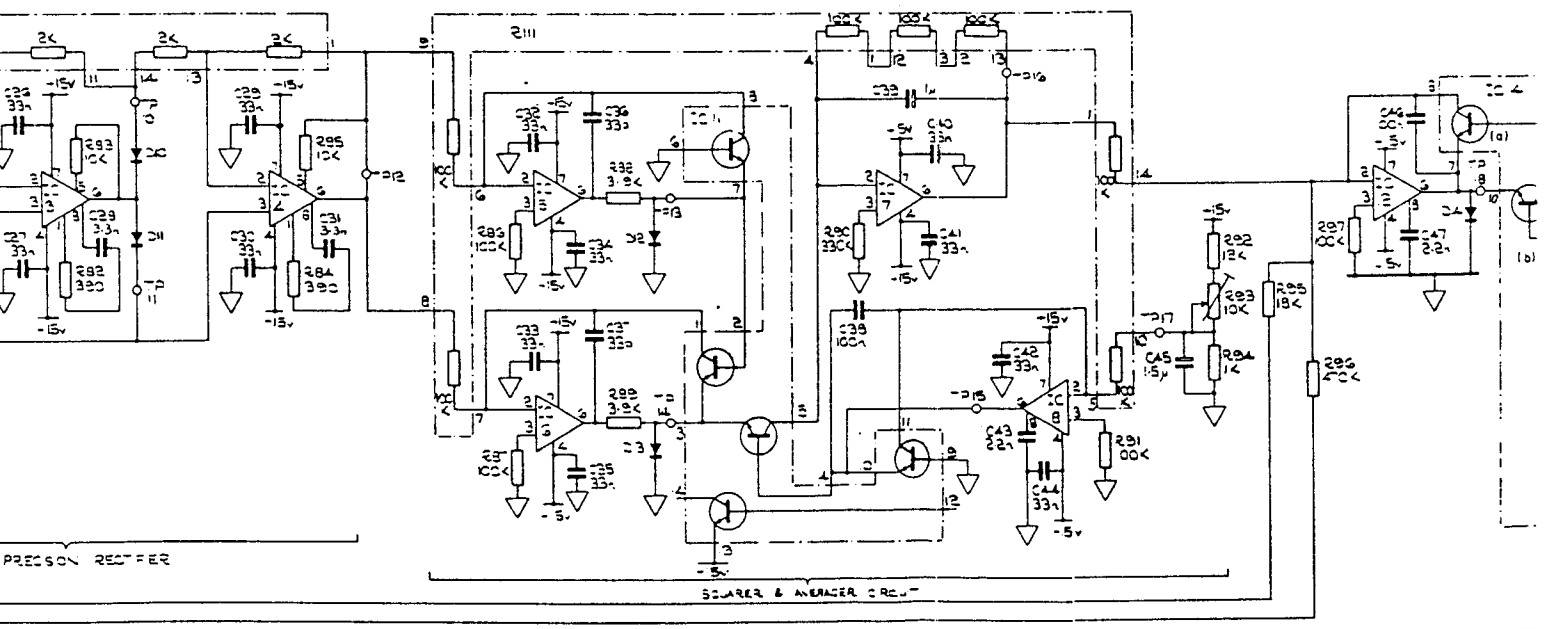
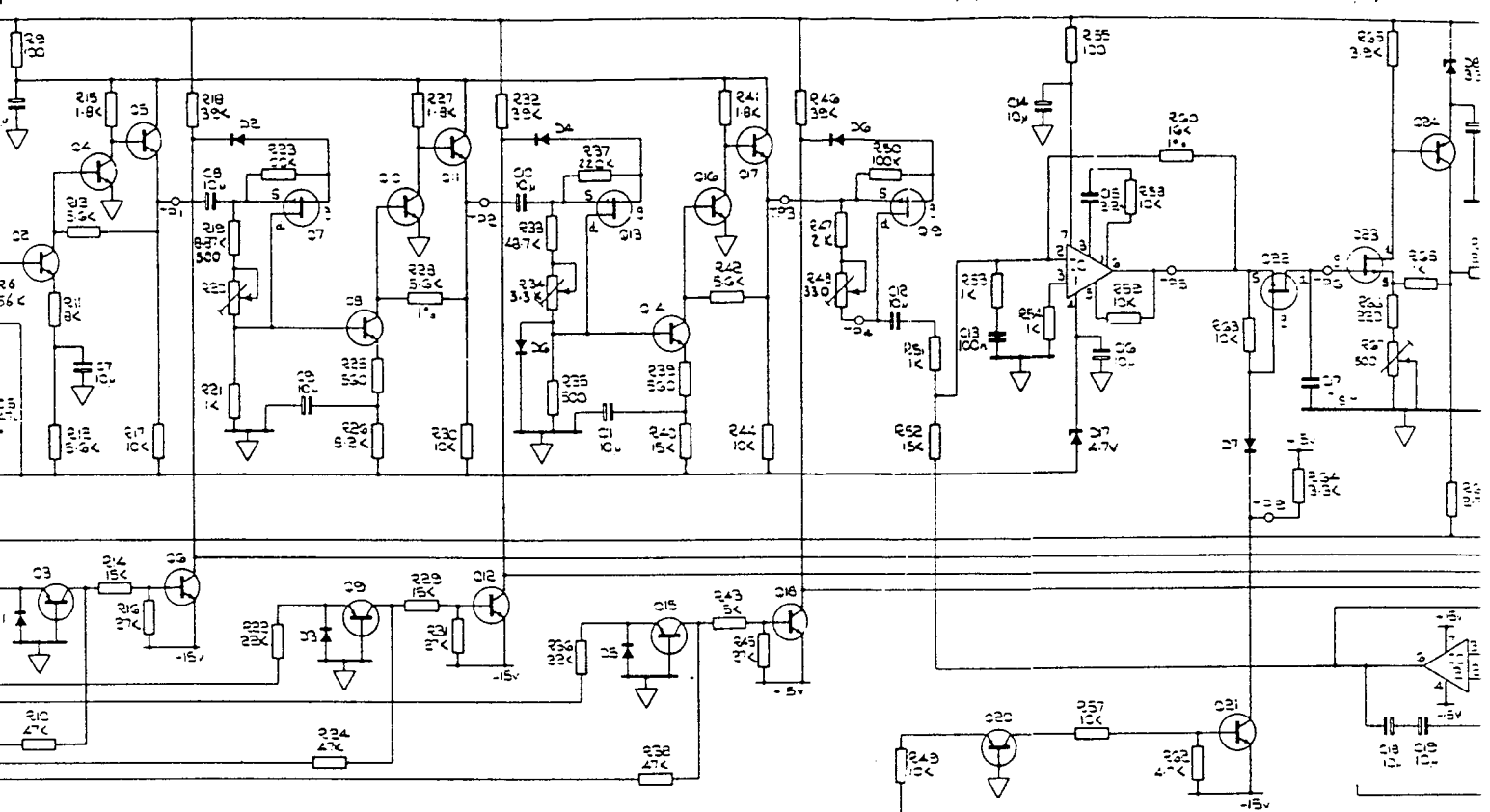

Circuit:

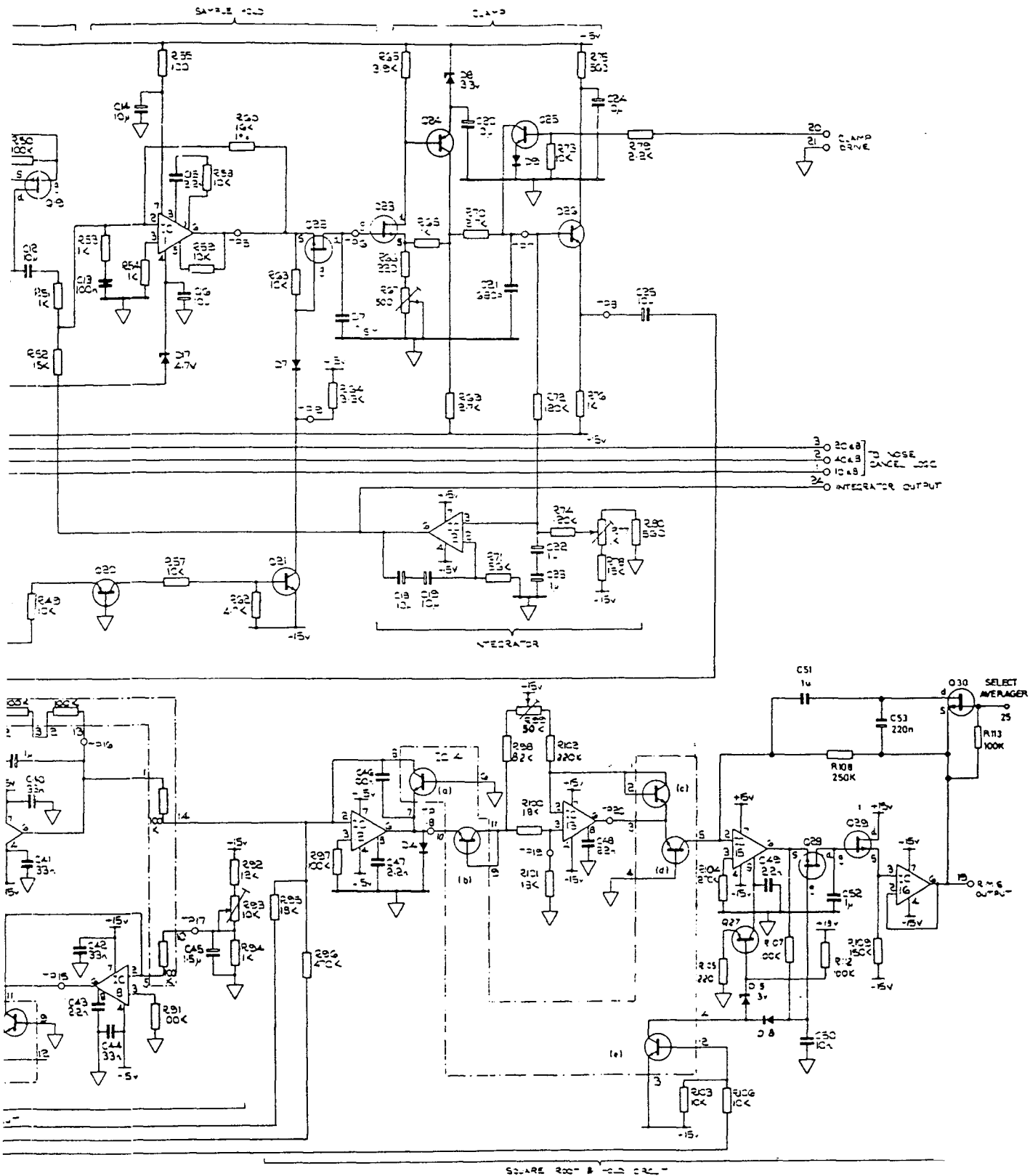

Circuit: Processor Assembly 19-0822

Fig. 9

